

**San Pedro Bay Ports Clean Air Action Plan  
Technology Advancement Program**



*Moving towards zero emissions*

TABLE OF CONTENTS

EXECUTIVE SUMMARY..... 1

1.0 TECHNOLOGY ADVANCEMENT PROGRAM.....4

    1.1 Introduction..... 4

    1.2 Technology Advancement Program Objectives..... 5

    1.3 Implementation Process..... 5

    1.4 Advisory Committee..... 6

2.0 KEY PROJECTS IN 2012 .....8

    2.1 Ocean-Going Vessels (OGVs)..... 9

        2.1.1 OGV Slide Valve Low-Load Emissions Evaluation..... 9

        2.1.2 Bluefield Holdings Krystallon Ocean Going Vessel Scrubber..... 13

    2.2 Locomotives ..... 16

        2.2.1 Johnson Matthey Locomotive DPF Demonstration..... 16

    2.3 Harbor Craft.....19

        2.3.1 Hug Filtersystems Tier 4 Harbor Craft Retrofit..... 19

    2.4 Cargo Handling Equipment ..... 22

        2.4.1 RYPOS Advanced Diesel Particulate Filter for Cargo Handling Equipment (CHE)..... 22

    2.5 Container Drayage Trucks ..... 24

        2.5.1 AQMD HDV In-Use Emissions Testing Program..... 24

        2.5.2 Vision Motor Corp. Hydrogen Fuel Cell Plug-In Hybrid Electric Trucks..... 26

3.0 WITHDRAWN PROJECTS.....29

4.0 ADDITIONAL PORT-RELATED ADVANCED TECHNOLOGY EFFORTS.....30

5.0 2012 TAP BUDGET .....34

6.0 TAP PRIORITIES FOR 2013 .....36

APPENDIX A: TECHNOLOGY ADVANCEMENT PROGRAM ADVISORY COMMITTEE

APPENDIX B: SUMMARY REPORTS FOR COMPLETED PROJECTS

**FIGURES**

Figure 2.1: MAN Model S70MC-C Marine Engine in Test Cell at Mitsui Engineering & Shipbuilding..... 10  
Figure 2.2: Gaseous Emissions Testing –Probe Inserted into Exhaust Duct Test Port ..... 12  
Figure 2.3: Schematic of the Krystallon Seawater Scrubber ..... 14  
Figure 2.4: JM System Installed on One Genset Engine of UP2737 ..... 17  
Figure 2.5: JM System Fully Installed on all three Gensets of UP2755 ..... 18  
Figure 2.6: Hug mobiclean® Diesel Particulate Filter System ..... 20  
Figure 2.7: The RYPOS HDPF/C™ System Installed on an RTG Crane..... 22

**TABLES**

Table 2.1: OGV Fuel Valve Testing Funding ..... 13  
Table 2.2: Seawater Scrubber Demonstration Funding Partners ..... 16  
Table 2.3: Johnson Matthey Locomotive DPF Demonstration Funding Partners..... 18  
Table 2.4: Comparison of Tier 2 Expected Emissions with and without Hug Mobiclean® ..... 21  
Table 2.5: Hug Filtersystems Tier 4 Retrofit Project Funding Partners..... 21  
Table 2.6: RYPOS ActiveDPF/C Demonstration Funding Partners..... 23  
Table 2.7: AQMD HDV In-Use Emissions Testing Program..... 26  
Table 5.1: TAP Funding Commitments through December 31, 2012 ..... 35

**ACRONYMS & ABBREVIATIONS**

AC	Advisory Committee
ACTI	Advanced Cleanup Technologies Incorporated
AMECS	Advanced Maritime Emissions Control System
APL	Shipping line formerly known as American President Line
AQIP	Air Quality Investment Program
CAAP	Clean Air Action Plan
CARB	California Air Resources Board
CCRT	catalyzed continuously regenerating technology
CEC	California Energy Commission
CEMS	continuous emissions monitoring system
CHE	Cargo Handling Equipment
CNG	compressed natural gas
CO	carbon monoxide
CO <sub>2</sub>	carbon dioxide
CRT	continuously regenerating technology
CSF	catalyzed soot filter
DOC	diesel oxidation catalyst
DPF	diesel particulate filter
DPM	diesel particulate matter
DPM <sub>10</sub>	diesel particulate matter – 10 micron diameter
DPM <sub>2.5</sub>	diesel particulate matter – 2.5 micron diameter
EGR	exhaust gas recirculation
EPA	United States Environmental Protection Agency
GCVWR	gross combined vehicle weight rating
GHG	greenhouse gases
H <sub>2</sub>	hydrogen
HC	harbor craft
HFO	heavy fuel oil
HHDDT	heavy heavy-duty diesel truck
HP	horsepower
HPDI	high pressure direct injection
IMO	International Maritime Organization
LNG	liquefied natural gas
MDO	marine diesel oil
MGO	marine gas oil
MOA	Memorandum of Agreement
MW	megawatt
NO	nitric oxide
NO <sub>2</sub>	nitrogen dioxide
NO <sub>x</sub>	oxides of nitrogen
nm	nautical miles
OGV	ocean going vessel
O <sub>2</sub>	oxygen
PAH	polycyclic aromatic hydrocarbon
PHL	Pacific Harbor Line
POLA	Port of Los Angeles

**ACRONYMS & ABBREVIATIONS (CONT'D.)**

POLB	Port of Long Beach
PON	Program Opportunity Notice
PM	particulate matter
PM <sub>10</sub>	particulate matter less than 10 micrometers in diameter
PM <sub>2.5</sub>	particulate matter less than 2.5 micrometers in diameter
RFI	Request for Information
RFP	Request for Proposals
RFQ	Request for Qualifications
RL	railroad locomotives
RTG	rubber tired gantry crane
SCAQMD	South Coast Air Quality Management District
SCR	selective catalytic reduction
SCRT	selective catalytic reduction technology
SiC	silicon carbide
SoCalGas	Southern California Gas Company
SO <sub>x</sub>	sulfur oxides
SO <sub>2</sub>	sulfur dioxide
SwRI	Southwest Research Institute
TAC	toxic air contaminant
TAP	Technology Advancement Program
U.S.	United States
VOC	volatile organic compound
VSR	vessel speed reduction
ZEV	zero-emission vehicle

## EXECUTIVE SUMMARY

The Ports of Long Beach and Los Angeles (Ports) comprise one of the world's premier seaport complexes and are recognized as global leaders in environmental stewardship. The Ports also serve as a principal economic engine for Southern California, moving over \$300 billion in trade each year and supporting more than 500,000 jobs in Southern California. Although economic conditions have caused a near-term reduction in imports and exports, the latest economic forecasts still indicate that demand for containerized cargo moving through the Southern California region will increase significantly by the year 2035. The Ports recognize that their ability to accommodate the projected growth in trade will depend upon their ability to address adverse environmental impacts that result from such trade.

The Ports' landmark joint Clean Air Action Plan (CAAP)<sup>1</sup> guides the Ports in their commitment to reduce the health risks and air emissions associated with port-related operations, while allowing port development and growth to continue. The CAAP focuses on near-term strategies, targeting significant reductions in diesel particulate matter (DPM), nitrogen oxides (NO<sub>x</sub>), and sulfur oxides (SO<sub>x</sub>). The CAAP also established a health risk reduction goal for 2020 and emissions reduction goals for the years 2014 and 2023.<sup>2</sup>

Over the past seven years, the Ports' CAAP has resulted in dramatic strides in reducing air emissions. CAAP programs like the Clean Trucks Program have slashed pollution from heavy-duty trucks. Green leases and state regulations have curbed emissions from cargo-handling equipment and harbor craft. Vessel speed reduction programs, accelerated shore-power deployment through lease requirements, and low-sulfur fuel regulations have led to significant drops in ship-related air pollution. Overall, between 2005 and 2011, the port-related DPM emissions were reduced by 73 percent, NO<sub>x</sub> emissions were reduced by 50 percent and SO<sub>x</sub> emissions were reduced by 78 percent. Despite this progress, the Ports still have work to do in order to meet the aggressive pollution-reduction goals defined in the 2010 CAAP Update.

In 2007, the Technology Advancement Program (TAP) was developed under the CAAP to ensure that effective air pollution reduction strategies will be commercially available to enable implementation of all CAAP measures. The purpose of the TAP is to identify and demonstrate new technologies or new applications of existing technologies that have a strong potential to reduce air pollution emissions from the CAAP source categories and meet CAAP goals. The Mission Statement for the TAP is to "accelerate the verification or commercial availability of new, clean technologies through evaluation and demonstration to move towards an emissions free port."

---

<sup>1</sup> 2006 San Pedro Bay Ports Clean Air Action Plan: <http://www.polb.com/civica/filebank/blobdload.asp?BlobID=3452>

<sup>2</sup> 2010 San Pedro Bay Ports Clean Air Action Plan Update: <http://www.cleanairactionplan.org/reports/documents.asp>

## San Pedro Bay Ports Technology Advancement Program 2012 Annual Report

The TAP is funded on an annual basis by both Ports. Each Port allocates \$1.5 million annually to new projects identified through the program. The Ports maximize the effectiveness of this investment by leveraging the Ports' funding with contributions from stakeholder agencies, including the United States Environmental Protection Agency Region 9 (U.S. EPA Region 9), California Air Resources Board (CARB), and South Coast Air Quality Management District (SCAQMD). Further, a minimum 50 percent co-funding contribution is required by the project applicant for all TAP projects. The TAP implementation process is thoroughly outlined in the TAP Guidelines<sup>3</sup>. The TAP offers grant funding to support the demonstration of advanced technologies that:

- a) Have a high probability of achieving significant reductions in criteria pollutants as well as CARB-classified air toxic pollutants, specifically, DPM, NO<sub>x</sub>, and SO<sub>x</sub>;
- b) Are seeking CARB verification for the technology; and
- c) Present a strong business case for future successful technology commercialization.

In the simplest terms, the purpose of the TAP is to facilitate the development of additional, effective air pollution reduction strategies for the CAAP "toolbox."

While the TAP primarily focuses on the demonstration of technologies that have a high potential to yield substantial criteria air pollutant reductions, the technologies demonstrated under the TAP often reduce greenhouse gases (GHG) and fine particulate matter (i.e., particle size of 2.5 micron in diameter, or smaller). As a matter of practice, GHG emission reduction potential is considered in the evaluation for each technology proposed for a TAP demonstration.

The TAP serves as the catalyst for identifying, evaluating, and demonstrating new and emerging emission reduction technologies applicable to the port industry. As envisioned by the Ports at the onset of program implementation, successful TAP technologies are intended to be incorporated into CAAP updates as either new control measures, alternatives to existing emission reduction strategies, or as additional mitigation options to support port growth.

The TAP Advisory Committee (AC) consists of agency partners that include the Port of Long Beach (POLB), Port of Los Angeles (POLA), SCAQMD, CARB, and U.S. EPA Region 9. A list of current AC members is included in Appendix A. The AC serves in an advisory capacity to the Ports for screening, evaluating, and recommending projects that merit further development or demonstration. In addition, the AC members provide information as it pertains to co-funding from their agency that could potentially be used to move projects toward implementation. The AC process also serves as the mechanism for member agencies and the Ports to reach consensus on the level of emission reductions achieved by the candidate technologies undergoing evaluation. As an example, in 2012, the Ports focused on the need for test plan guidelines that could be used to evaluate OGV emission control technologies. This effort was coordinated by CARB and resulted in the publication<sup>4</sup> of the "Recommended Emissions Testing Guidelines for Ocean-going Vessels (OGV)," which were used to evaluate the TAP's Krystallon Seawater Scrubber technology.

---

<sup>3</sup><http://www.cleanairactionplan.org/civica/filebank/blobdload.asp?BlobID=2489>

<sup>4</sup><http://www.arb.ca.gov/ports/marinevess/documents/emissiontest/OGV%20Test%20Guidelines.pdf>

**San Pedro Bay Ports Technology Advancement Program**  
2012 Annual Report

This is the sixth TAP Annual Report under the CAAP. The 2012 TAP Annual Report documents progress with the Ports' efforts to support near-term emerging technology development and demonstration. This Annual Report includes a summary of the seven (7) projects that were either selected or continued to be implemented under the TAP during 2012. These include:

<b>Source Category</b>	<b>TAP Project</b>
<ul style="list-style-type: none"> <li>▪ Ocean Going Vessels</li> </ul>	<ul style="list-style-type: none"> <li>OGV Slide Valve Low-Load Emissions Evaluation</li> <li>Bluefield Holdings Inc./Krystallon OGV Scrubber</li> </ul>
<ul style="list-style-type: none"> <li>▪ Locomotives</li> </ul>	<ul style="list-style-type: none"> <li>Johnson Matthey Locomotive DPF Demonstration</li> </ul>
<ul style="list-style-type: none"> <li>▪ Harbor Craft</li> </ul>	<ul style="list-style-type: none"> <li>Hug Filtersystems Tier 4 Harbor Craft Retrofit</li> </ul>
<ul style="list-style-type: none"> <li>▪ Cargo Handling Equipment</li> </ul>	<ul style="list-style-type: none"> <li>RYPOS Advanced Diesel Particulate Filter for Cargo Handling Equipment</li> </ul>
<ul style="list-style-type: none"> <li>▪ Container Drayage Trucks</li> </ul>	<ul style="list-style-type: none"> <li>Vision Motor Corp. Hydrogen Fuel Cell Hybrid Electric Trucks (Zero-TT and Tyrano)</li> <li>AQMD Heavy-Duty Vehicle In-Use Emissions Testing Program</li> </ul>

Each of the aforementioned projects listed is discussed in Section 2 of this 2012 TAP Annual Report. In addition to the initiation or continued implementation of the above projects, the following projects concluded in 2012:

- RYPOS Advanced Diesel Particulate Filter for Cargo Handling Equipment
- Vision Motor Corp. Hydrogen Fuel Cell Hybrid Electric Trucks (Zero-TT and Tyrano)

Please see Appendix B for complete summaries of these projects, as well as the other 16 projects completed by the TAP.



## 1.0 Technology Advancement Program

### 1.1 Introduction

The Ports of Long Beach and Los Angeles (Ports) comprise one of the world's premier seaport complexes and are recognized as global leaders in environmental stewardship. The Ports also serve as a principal economic engine for Southern California, moving \$300 billion in trade each year and supporting more than 500,000 jobs in Southern California. Although economic conditions have resulted in a reduction in imports and exports, the latest economic forecasts still indicate that the demand for containerized cargo moving through the Southern California region will increase significantly by the year 2035. The Ports recognize that their ability to accommodate projected growth in trade will depend upon their ability to address adverse environmental impacts that result from such trade.

While the economic benefits of the Ports are felt throughout the nation, the environmental impacts of trade are more locally concentrated. The Ports are cognizant of the view expressed by environmental groups, local residents, and regulatory agencies that more should be done to address port-related air quality issues. The Ports understand that inconsistent or conflicting environmental measures could have unintended and even counterproductive results.

In 2006, the Ports adopted their landmark joint Clean Air Action Plan (CAAP). The CAAP, which was updated in 2010 (2010 CAAP Update), guides the Ports in their commitment to reduce the health risks and air emissions associated with port-related operations, while allowing port development and growth to continue. The CAAP focuses on near-term strategies and targeting significant reductions in diesel particulate matter (DPM), nitrogen oxides (NO<sub>x</sub>), and sulfur oxides (SO<sub>x</sub>). DPM is of particular concern as it is linked to cancer and other serious health effects. NO<sub>x</sub> and SO<sub>x</sub> are contributors to the region's ozone smog and fine particulate matter levels, which are also important health concerns. The CAAP also established a health risk reduction goal for 2020 and emissions reduction goals for the years 2014 and 2023.

Over the past seven years, the Ports have made dramatic strides in reducing air emissions. CAAP programs like the Clean Trucks Program have slashed pollution from heavy-duty trucks. Green leases and State regulations have curbed emissions from cargo-handling equipment and harbor craft. Accelerated shore-power deployment through lease requirements and low-sulfur fuel regulations have led to significant drops in ship-related air pollution. Overall, between 2005 and 2011, port-related DPM emissions were reduced by 73%, NO<sub>x</sub> emissions were reduced by 50% and SO<sub>x</sub> emissions were reduced by 78%. Despite this progress, the Ports still have work to do in order to meet the aggressive pollution-reduction goals defined in the 2010 CAAP Update.

This document is the sixth Technology Advancement Program Annual Report under the CAAP.

## 1.2 Technology Advancement Program Objectives

The TAP Mission Statement is to “accelerate the verification or commercial availability of new, clean technologies through evaluation and demonstration to move towards an emissions free port.”

The TAP thus serves as the catalyst for identifying, evaluating, and demonstrating new and emerging emissions reduction technologies applicable to the port industry. These technologies will be incorporated in future updates to the CAAP as either new control measures, alternatives to existing emission reduction strategies, or as additional mitigation options to support port growth.

The emphasis of the TAP is to facilitate testing or distribution of information on emerging technologies that can be used to reduce emissions associated with the five port-related source categories. These source categories include the following:

- Ocean Going Vessels
- Harbor Craft
- Cargo Handling Equipment
- Heavy-Duty Diesel Trucks
- Railroad Locomotives

## 1.3 Implementation Process

There are three primary means by which projects are identified for demonstration in the Technology Advancement Program:

### *Port Generated Projects*

Should the Ports have specific interest in an emissions reduction technology or project, the Ports may elect to develop a project, seek partnerships to demonstrate the technology in port applications, and manage the implementation of the project. The Ports may also seek grant funding from other stakeholders to assist with project implementation. In 2012, the OGV Slide Valve Low-Load Emissions Evaluation was a new Ports-sponsored project generated under the TAP. Ports’ staff pursued this project as part of CAAP goals to continuously review and enhance the emissions inventories and understanding of port emission reduction strategies. This project is discussed in Section 2.

### *Solicited Proposals*

The Ports enjoy broad authority under the TAP to solicit proposals for a specific technology or for technologies that are applicable to specified source categories. Common methods of soliciting projects include Requests for Information (RFI), Requests for Proposals (RFP), Requests for Qualifications (RFQ), and Program Opportunity Notices (PON).

### *Unsolicited Proposals*

The Ports frequently receive requests to fund various technology advancement projects, either from Port tenants working with technology providers, regulatory agencies conducting research or demonstration projects, or from technology developers/providers directly. When an unsolicited proposal is received by Port staff, it is evaluated using the following criteria:

- Technology Application – *Is the technology applicable to the port industry? Is the application feasible?*
- CARB Verification – *Is the technology developer currently seeking, or are they willing to seek, CARB verification?*
- Matching Funds – *Is the project supported by in-kind or direct capital matching funds?*
- Emission Reductions – *Are the emission reductions consistent with the 2010 CAAP Update goals? Does the technology reduce some emissions without increasing others?*
- Ability to meet the needs of the port industry – *Will the technology perform effectively in the port environment?*
- Uniqueness of the Proposal – *Is the technology new or emerging, at the pre-commercialization stage? Has the technology or demonstration been proposed by multiple vendors?*
- Cost – *Is the cost for the technology reasonable?*
- Industry Support – *Does the project have a committed port-industry partner willing to demonstrate the technology?*

Unsolicited proposals that are deemed meritorious by Port staff are forwarded to the TAP Advisory Committee for further review. During the 2012 calendar year, a number of unsolicited proposals were submitted for TAP consideration. Several of these proposals continue to be under review and staff hopes that meritorious proposals would be initiated in 2013.

## **1.4 Advisory Committee**

The TAP Advisory Committee (AC) consists of agency partners that include the Ports, SCAQMD, CARB, and U.S. EPA Region 9. The AC was established by invitation during the first quarter of 2007 and meets every six weeks to deliberate the merits of proposed TAP projects.

The AC serves in an advisory capacity to the Ports for screening, evaluating, and recommending projects to be considered for further development or demonstration. The AC review serves as the mechanism for member agencies and the Ports to reach consensus on the level of emission reductions achieved by the candidate technologies undergoing evaluation.

The stated goal of the TAP program is to accelerate the development, verification, and commercialization of technologies that reduce source category air pollution emissions. The Ports seek participation and funding contributions from other agencies for TAP projects. In this context, the AC members identify potential agency co-funding that could support TAP projects.

## San Pedro Bay Ports Technology Advancement Program 2012 Annual Report

In 2012, the Ports received a number of unsolicited proposals submitted for funding consideration under the TAP. Due to the wide range of technologies proposed, the AC membership was augmented on an ad-hoc basis to include additional members from the partnering agencies with expertise in diverse areas such as fuel additives, diesel emission control systems, and marine vessels. A list of current AC members is included in Appendix A of this Annual Report.



## 2.0 Key Projects in 2012

This sixth Technology Advancement Program Annual Report includes a summary of the seven (7) projects that were implemented or remained active in 2012. These include:

<b>Source Category</b>	<b>TAP Project</b>
▪ Ocean Going Vessels	OGV Slide Valve Low-Load Emissions Evaluation Bluefield Holdings Inc./Krystallon OGV Scrubber
▪ Locomotives	Johnson Matthey Locomotive DPF Demonstration
▪ Harbor Craft	Hug Filtersystems Tier 4 Harbor Craft Retrofit
▪ Cargo Handling Equipment	RYPOS Advanced Diesel Particulate Filter for Cargo Handling Equipment
▪ Container Drayage Trucks	Vision Motor Corp. Hydrogen Fuel Cell Hybrid Electric Trucks (Zero-TT and Tyrano) AQMD Heavy-Duty Vehicle In-Use Emissions Testing Program

A summary and status update for each of the projects listed above is discussed in this Annual Report (Section 2).

Two (2) of these TAP projects ended during 2012, as noted below. A summary of each newly concluded TAP project, as well as all TAP projects completed to date, is included in Appendix B.

1. RYPOS Advanced Diesel Particulate Filter for Cargo Handling Equipment
2. Vision Motor Corp. Hydrogen Fuel Cell Hybrid Electric Trucks (Zero-TT and Tryano)

## 2.1 Ocean-Going Vessels (OGVs)

### 2.1.1 OGV Slide Valve Low-Load Emissions Evaluation

In 2008, the Port of Los Angeles and the Port of Long Beach participated in a demonstration of slide-type fuel valves to quantify their effectiveness as an emissions reduction retrofit technology for OGVs equipped with Tier 0 and Tier 1 two-stroke diesel main engines<sup>5</sup> manufactured by MAN Diesel & Turbo/PrimeServ (MAN).

The demonstration was conducted aboard the APL Singapore. This new type of OGV main engine fuel valve is designed to improve combustion properties by eliminating sac volume (i.e., fuel drips) at the valve nozzle. The elimination of the sac volume results in lower fuel oil consumption. In addition, slide valve nozzles incorporate an optimized spray pattern designed to improve the combustion process - this is intended to reduce overall emissions, including hydrocarbon, NO<sub>x</sub>, and particulate matter. The visible smoke level is also greatly reduced as a result of the improved combustion.

The manufacturer, MAN, had previously published data suggesting slide valves offered a potential for a 30 percent reduction in NO<sub>x</sub> emissions and 25 percent reduction DPM emissions when the technology is optimized in new engines.

The results from the 2008 APL Singapore slide valve retrofit demonstration were, however, inconclusive, suggesting that the use of slide valves as an OGV main engine retrofit technology may not provide the level of emission reductions originally anticipated. In addition to the APL data, new information provided by the manufacturer also indicated that potential benefits from slide valves could be eroded as engine load is reduced. In San Pedro Bay, ships complying with the vessel speed reduction (VSR) program generally have main engine loads below 25 percent, which is the lowest load point at which slide valves had been previously tested. Discussions with MAN determined that there had been no low-load engine tests for slide valve emission reductions conducted specifically on large slow-speed, two-stroke propulsion engines below 25 percent load and, therefore, there are no data to determine whether the slide valve benefit is appropriate at these lower loads.

Based on the previous information, the Ports' Emissions Inventory Technical Advisory Committee had recommended that the emission reduction benefits associated with slide valves be applied in both Ports' emissions inventories for all vessel main engine loads. Due to the high participation levels of vessels complying with the VSR program, the Ports determined that additional data were necessary to validate this benefit, and therefore sponsored additional emissions testing to determine what, if any, benefit results from MAN slide valves, especially at engine loads below 25 percent.

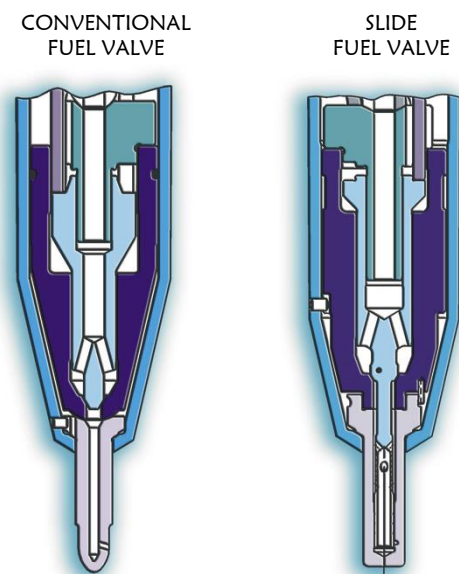

<sup>5</sup> New Tier 2 vessels already incorporate slide valves and therefore no additional reduction is applicable to their use.

This testing was conducted in support of the CAAP OGV Measure 6 (OGV6) and is intended to better understand the benefits of the use of this technology and improve the estimates included in the annual emissions inventories.

### *Test Program Overview*

The Ports, with support from their project partners, developed a comprehensive test plan to quantify emissions from OGV fuel valves as a function of fuel valve nozzle design and engine load. Three fuel valve nozzle designs underwent performance and emissions testing:

- Slide-valve nozzle C26 – this is standard equipment on new slow-speed marine diesel engines manufactured by MAN and its licensees;
- Conventional C3 nozzle – this is the fuel valve design used on Tier 0 and Tier 1 MAN marine diesel engines;
- Conventional C11 nozzle – this is a “low-NOx” conventional fuel valve, equipped with a nozzle that delivers a fuel spray pattern designed to minimize NOx emissions.

The MAN S70MC-C marine diesel engine was selected as the test bed for the low-load emissions testing. This six-cylinder, slow-speed two-stroke marine engine was selected based on call activity data from both Ports over the past several years and is the most representative propulsion engine available for testing in the fleet of vessels that has called at both Ports.

**Figure 2.1: MAN Model S70MC-C Marine Engine in Test Cell at Mitsui Engineering & Shipbuilding**

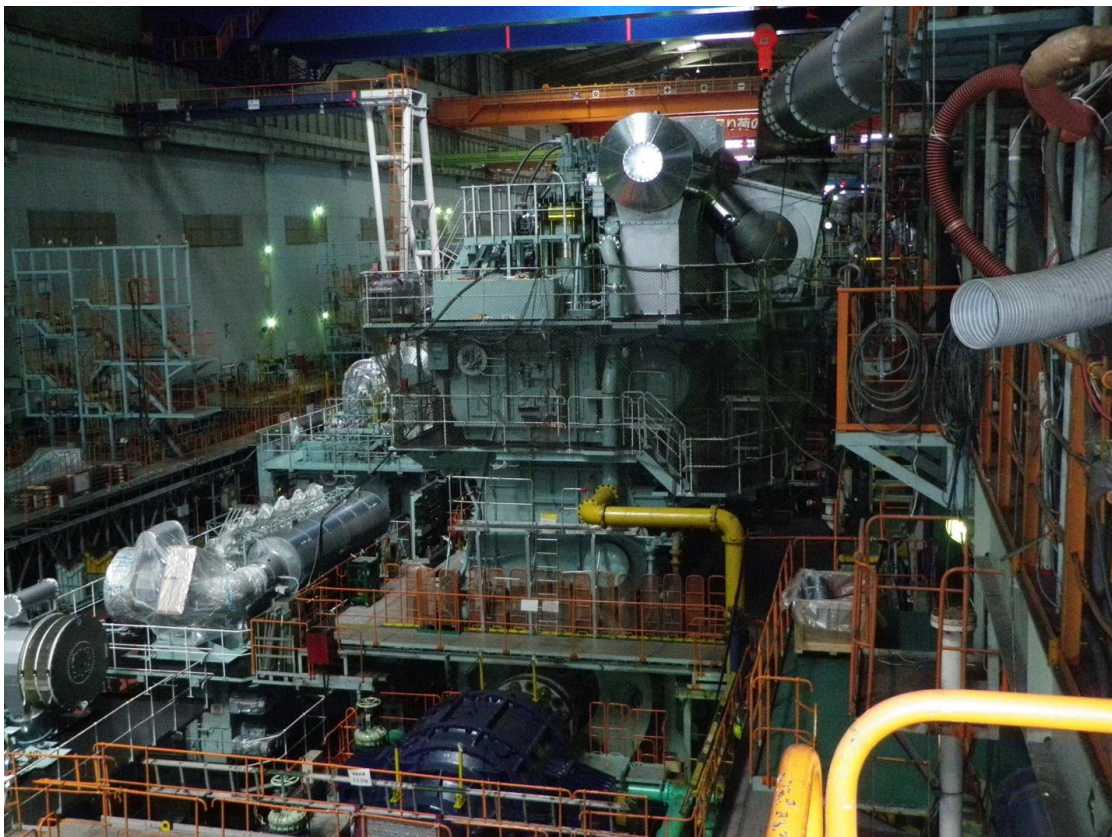

Three test cycles consisting of the following load profiles were specified for each fuel valve configuration:

- Test Cycle #1: Engine loads of the ISO E3 test cycle (25, 50, 75 and 100 percent) while temperature is stable;
- Test Cycle #2: Engine load of 15% while temperature is stable;
- Test Cycle #3: Engine load of 10% while temperature is stable.

Testing methods specified in the test plan were consistent with methods outlined in Chapter 5 of the IMO MARPOL Annex VI, NO<sub>x</sub> Technical Code 2008 (2009 Edition), and ISO8178. Performance parameters measured included the following:

- Engine exhaust temperature (°C);
- Total fuel consumption (metric tons);
- Fuel consumption rate at test loads (metric tons/hour);
- Engine output in kilowatts (kW); and
- Pressures and temperatures equivalent to a 'standard MAN B&W observation form', including specific fuel oil consumption (SFOC).

The following exhaust compounds were specified for measurement and reporting in units of g/kW-hr:

- Oxides of nitrogen (NO<sub>x</sub>)
- Nitrogen oxide (NO)
- Hydrocarbons (HC)
- Carbon monoxide (CO)
- Carbon dioxide (CO<sub>2</sub>)
- Particulate matter (PM) & soot
- Total hydrocarbons (THC)
- Oxygen (O<sub>2</sub>)

### *Testing Implementation*

Testing was conducted during the week of September 24, 2012 at Mitsui Engineering & Shipbuilding, located in Tamano, Japan. The testing team consisted of:

- MAN Diesel & Turbo/PrimeServ (MAN), Department DR-CPH, Copenhagen, Denmark;
- Mitsui Engineering & Ship Building Co., LTD (Mitsui), Tamano Works, Tamano, Japan;
- Starcrest Consulting Group, LLC (Starcrest), Poulsbo, WA



Figure 2.2: Gaseous Emissions Testing –Probe Inserted into Exhaust Duct Test Port



MAN's role, as engine design licensor, was to provide technical support relating to the testing and perform emissions and dilution tunnel measurements following ISO 8178 for particulate matter. Mitsui, as engine manufacturer licensee, provided the MAN Model S70MC-C two-stroke marine diesel engine used in the emissions testing. Mitsui also assumed the lead role in conducting performance and gaseous pollutant measurements. Mitsui also modified the existing test bed exhaust configuration at Tamano Works to allow MAN to conduct particulate matter testing. Starcrest's role was to provide testing coordination among MAN, Mitsui, and the Port; coordination with the TAP AC; and provide third-party oversight of the testing.

Testing was conducted over three consecutive days, with each of the three fuel valve nozzle configurations requiring one full testing day for installation, engine warm-up, and emissions measurement. Fuel used during the testing was Japanese-blend marine diesel oil, whose measured sulfur content was 0.08 percent - this was deemed compliant with the CARB Ocean-Going Vessel Fuel Rule, which will require use of  $\leq 0.1\%$  sulfur distillate fuel within 24 nautical miles of the California coast starting in 2014 and the North American Emissions Control Area, which will require  $\leq 0.1\%$  sulfur fuel within 200 nautical miles of the North American coast in 2015.

The three fuel nozzles (two conventional (C3, #3137901-2 & C11, #3138323-0) and one slide-valve type (C26, 1767890-6)) were tested at six loads (10, 15, 25, 50, 75 and 100 percent, the ISO E3 cycle plus two low loads) following standard IMO Annex VI, NTC 2008 and ISO 8178 procedures. In addition to ISO 8178, EPA Method 17 dust measurements and Bosch type soot measurements were taken.

### *Testing Results*

Preliminary results indicate that under identical operating conditions the slide valve offers improved fuel consumption at low-load conditions compared to the conventional and conventional Low-NO<sub>x</sub> fuel valve nozzles. The Low-NO<sub>x</sub> nozzle (C11) demonstrated the highest fuel consumption. At high engine loads above approximately 90 percent, no major difference in specific fuel oil consumption exists. The total hydrocarbon (THC) measurement data reflect the slide valve benefit - low THC emission levels corresponding to the slide valve's substantial

elimination of the fuel sac volume. The relative reductions in THC emissions between the slide and conventional fuel valves are greatest at engine loads below 25 percent. The final report detailing all of the results is anticipated in mid-2013.

***Project Partners & Funding***

Total TAP funding applied to the slide valve low-load emissions evaluation is \$216,000, as shown below in Table 2.1. Each Port contributed 50 percent of the total project cost.

**Table 2.1: OGV Fuel Valve Testing Funding**

Project Partners	Contributions
<ul style="list-style-type: none"> <li>▪ Port of Long Beach</li> </ul>	\$108,000
<ul style="list-style-type: none"> <li>▪ Port of Los Angeles</li> </ul>	\$108,000

***Environmental Benefits***

The anticipated results of this TAP-sponsored testing program preliminarily indicate that a slide valve retrofit program targeting Tier 0 and Tier 1 OGV main engines manufactured by MAN is not an effective NOx reduction strategy, especially when considering the low engine loads experienced by vessels complying with the VSR program. Slide valves are, however, very effective in reducing hydrocarbon emissions and are anticipated to be equally effective in reducing particulate matter emissions. Further, preliminary data also indicate that slide valves offer the lowest specific fuel oil consumption compared to conventional fuel valves. These benefits are greatest at the low engine loads associated with VSR speeds. It is noteworthy that the slide valve offers GHG emission reductions compared to conventional fuel valves. However, the magnitude of the reduction is relatively small at approximately 2.5% - 3% at VSR engine loads (10% - 15% load).

***Project Status***

Emissions testing results will be provided in a summary report detailing testing methods used, actual conditions, supporting data, and results. Raw and summarized data will be provided in an appendix. This report is anticipated in mid-2013.

***2.1.2 Bluefield Holdings Krystallon Ocean Going Vessel Scrubber***

The Bluefield Holdings/Krystallon seawater scrubber is an advanced emission control technology for Ocean Going Vessels (OGV). For this technology, seawater is used to “scrub,” or filter, particulate contaminants from the vessel exhaust stream before the exhaust is emitted to the atmosphere. The washwater is treated to remove contaminants and chemical constituents and the pH is then adjusted to be compatible with seawater, before it is returned to the ocean. All recovered washwater contaminants are stored onboard the vessel until they can be properly disposed of ashore.

*Emission Control Technology*

For this TAP project, Bluefield Holdings installed, demonstrated, and quantified the emission reduction capabilities of a seven (7) megawatt (MW) Krystallon SC 500 scrubber on the APL England, an APL C-11 class container ship. This was the first SC 500 type scrubber built by Krystallon to be commissioned and installed on an OGV. The Krystallon scrubber was configured to treat the combined emissions from three auxiliary engines. The design schematic is provided in Figure 2.3, and includes gas separation prior to the inlet of the scrubber, allowing the emissions from the boiler and all of the auxiliary engines to be treated simultaneously, or individually. This allows the most flexibility for the vessel and reduces the maximum emissions for the lowest capital investment and operating cost.

**Figure 2.3: Schematic of the Krystallon Seawater Scrubber**

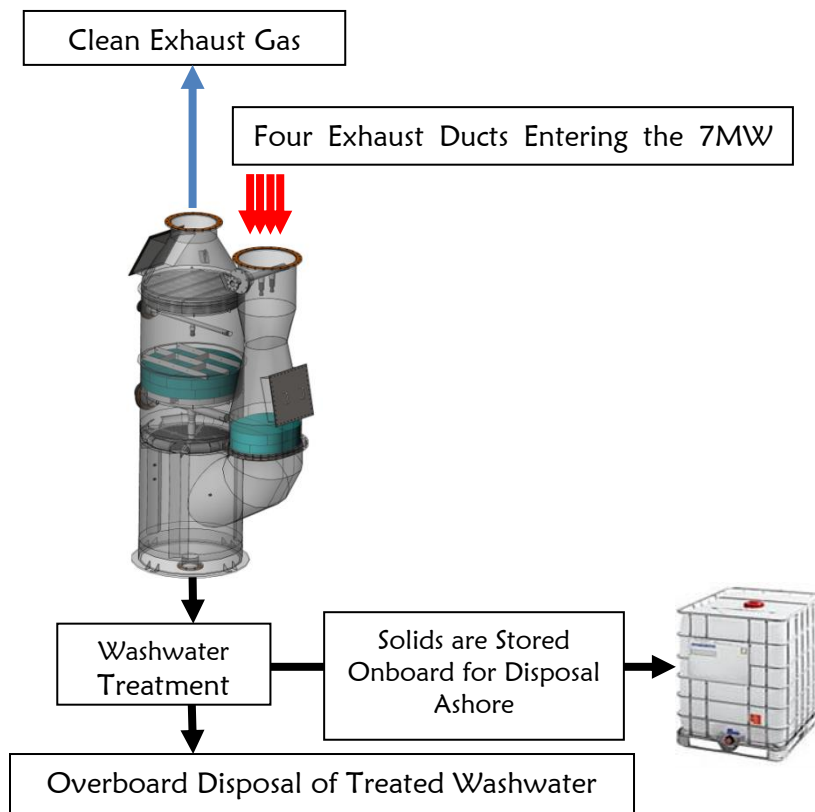

The demonstration plan included operating the scrubber within 200 nautical miles (nm) from shore all the way to the berth. Heavy fuel oil (HFO), compliant with International Maritime Organization (IMO) regulations at the time of the evaluation, was used in all engines from 200 nm to 24 nm; distillate fuel compliant with CARB regulation, was used within 24 nm of the California coast.

A real-time continuous emissions monitoring system (CEMS) was included as a component of the scrubber system. The CEMS data compared favorably with the observed measured emissions. The CEMS allows the project team to track emissions from the scrubber. The continuous monitoring equipment functions whenever the scrubber is operating. Average and instantaneous measurements are made for:

- Carbon monoxide (CO)
- Carbon dioxide (CO<sub>2</sub>)
- Nitric oxide (NO)
- Sulfur dioxide (SO<sub>2</sub>)
- Water (H<sub>2</sub>O)

A washwater monitoring system installed on the APL England contains sensors on the intake and discharge lines to measure the following:

- Temperature, turbidity, PAH at intake and outlet
- Washwater supply pressure to the scrubber
- Temperature, PAH, pH and turbidity downstream of the treatment plant
- Temperature at washwater discharge
- Differential pressure across the water treatment plant
- Exhaust gas pressure at the scrubber inlet
- Exhaust gas pressure at the scrubber outlet

In addition to the CEMS, a third party contractor collected and analyzed discreet emission samples, including DPM, while at berth. This testing included engine operation emission results while the engines were using both residual fuel oil and marine distillate fuels. Sampling and testing of emissions and treated washwater took place at berth in the US and while underway between Taiwan and mainland China.

#### *Project Partners & Funding*

Significant prior investments have been made by the technology developer during the development of the multi-engine Krystallon SC 500 scrubber to be demonstrated under this TAP project. The Bluefield Holdings/Krystallon team invested over \$15 million developing and commercializing seawater scrubber technology for heavy marine engines, and significant additional corporate investments were made in the Krystallon SC 500 scrubber designed specifically for the APL project. In addition to these prior investments, Krystallon paid all costs to inspect the vessel, prepare submittals to the classification society, deliver final installation drawings to the owner and shipyard, as well as provided all supervision during the installation and commissioning process.

The TAP funding contributions were used to partially offset the costs associated with the scrubber equipment, as well as scrubber installation, testing, and reporting. Total TAP funding applied to the seawater scrubber demonstration was \$1.65 million, as noted below in Table 2.2.

**Table 2.2: Seawater Scrubber Demonstration Funding Partners**

Project Partners	Contributions
▪ Port of Long Beach	\$825,000
▪ Port of Los Angeles	\$825,000
▪ Bluefield/Krystallon	\$1,740,000

***Environmental Benefits***

Both emissions and discharges from the scrubber were tested using EPA standard test methods and supplemented by an onboard CEMS. With the scrubber running HFO fuel, sulfur reductions were in the range of 98 to 99 percent and PM reductions ranged from 56 to 70 percent. There were only minimal reductions of NO<sub>x</sub> (2 to 5 percent) when operating on HFO. When the scrubber ran marine gas oil (MGO) fuel, sulfur reductions ranged from 95 to 97 percent and PM reductions ranged from 68 to 75 percent. There were only minimal reductions of NO<sub>x</sub> (2 to 8 percent) when operating on MGO. Since there is less PM in MGO, the scrubber can remove a higher percentage of PM in MGO than in HFO.

Testing of the material removed from the scrubber indicated the removal of solids down to 0.8 microns. These fine and ultrafine particles are typically composed of elemental carbon with adsorbed compounds such as polycyclic aromatic hydrocarbons (PAH), sulfate, nitrate, metals and other trace elements. These very small particles are lighter and they stay airborne longer and travel farther from the source. PM<sub>10</sub> particles generally stay in the air for minutes or hours and travel as little as hundreds of yards while PM<sub>2.5</sub> and smaller particles can stay in the air for days or weeks and can potentially travel many hundreds of miles. The anticipated large reductions of DPM brought about by this project will be immediate; it is expected that significantly more DPM will be removed by the scrubber than simply running distillate fuel in the auxiliaries and boiler.

***Project Status***

The APL vessel completed its four-call requirement in August 2012. The draft final report documenting the results of the scrubber’s performance throughout the demonstration, and emissions reduction efficiency levels, was submitted to the Ports for review in late 2012. Based on this review, additional testing was conducted to alleviate concerns with the metal particles initially found in the discharge water. This additional testing was conducted in early 2013 and results will be included in the final report, which is anticipated in mid-2013.

**2.2 Locomotives**

***2.2.1 Johnson Matthey Locomotive DPF Demonstration***

The Ports, in conjunction with CARB, SCAQMD, Union Pacific Railroad and Johnson Matthey (JM) have partnered to demonstrate and evaluate the effectiveness of a JM diesel particulate filter (DPF) as an aftertreatment device on a Union Pacific Railroad Switcher Locomotive equipped with three (3) Tier 3 700 horsepower (hp) gensets (total 2,100 hp). Once installed, it is anticipated that the JM system will help the Tier 3 engines meet Tier 4 PM emission standards, with additional reductions in CO and hydrocarbon emissions. This project will demonstrate the transferability of JM’s DPF technology, which is typically used in on-road heavy-duty vehicle applications, to an off-road locomotive application.

CARB's Air Quality Investment Program (AQIP) grant to the SCAQMD is funding the technology development and demonstration phases of this project. The demonstration requires 3,000 engine hours of operation, and will determine the durability of the JM system against the shock and vibrational forces experienced during standard switcher locomotive operation. TAP project funding is programmed to cover emissions testing throughout the project and support the technology verification effort.

### *Emission Control Technologies*

The JM Switcher Locomotive DPF System consists of multiple DPF, DOC, and catalyzed soot filter (CSF) components and is expected to achieve greater than 85 percent PM reduction, which allows Tier 3 engines to meet federal Tier 4 locomotive engine emission standards for PM. The Catalyzed Continuously Regenerating Technology (CCRT) system is a modified version of JM's Continuously Regenerating Technology (CRT) used in on-road applications, with the addition of a specialized coating to the filter. The coating enhances the passive regeneration potential of the system at lower temperatures. According to JM, lower DPF regeneration temperatures are important in a switcher locomotive application because locomotive engines have a temperature profile that is too low for other types of DPFs with the significant amount of time spent at idle. Additionally, the system is designed with a feature to minimize back pressure that helps to increase the service life between filter cleanings.

The design modifications made to the CCRT for this project consist of multiple DOC and CSF pairs. The sizing of the system and the choice of specific DOC and CSF depends on the exhaust characteristics of the engine. JM conducted baseline testing on a 2007 model year, QSK19 engine at Southwest Research Institute (SwRI) and gathered useful data on the engine out temperature, exhaust flow, and emissions. From this testing, an alpha system was designed and installed on one of the three genset engines of Union Pacific switcher UPY2737 (Figure 2.4). This earlier test served as a precursor to the current CARB AQIP demonstration, in which Union Pacific switcher UP2755 (Figure 2.5) was completely fitted with three DOC and CSF pairs (one for each genset).

**Figure 2.4: JM System Installed on One Genset Engine of UP2737**



Figure 2.5: JM System Fully Installed on all three Gensets of UP2755



**Project Partners & Funding**

The total budget for this project is \$692,356, of which JM committed \$146,246 in cash match funding (21 percent total). Half of the project costs are being covered by a fiscal year (FY) 2011-2012 CARB AQIP grant in the amount of \$346,178, to support the durability demonstration effort. As a CARB policy, State funding cannot be expended to support verification-related expenses since CARB is the agency responsible for verifying emission reduction benefits of clean air technologies. In order to facilitate verification of this project (i.e., emissions testing and verification costs), TAP funding in the amount of \$150,000 (\$75,000 per Port) was committed to the project.

Project costs are shown below in Table 2.3.

**Table 2.3: Johnson Matthey Locomotive DPF Demonstration Funding Partners**

Project Partners	Contributions
Port of Long Beach	\$75,000
Port of Los Angeles	\$75,000
California Air Resources Board (via AQIP)	\$346,178
Johnson Matthey	\$146,246
Union Pacific	\$49,932

### *Project Status*

Design and installation of the JM system began in early 2011. After successful installation, the zero-hour emissions testing showed the JM system achieved Tier 4 PM emission levels. The retrofitted switcher was placed into Union Pacific's revenue service on July 11, 2011 in fulfillment of the engine-hour durability testing requirement per the CARB AQIP agreement. As of December 31, 2012, there were approximately 2,500 engine hours accrued on the switcher unit. Upon completion of the first 1,500 hours, the switcher was sent to SwRI, in San Antonio, TX to undergo the second round of emissions testing. Preliminary results from the 1,500 hour summary report demonstrate that the JM system performed well, averaging below Tier 4 levels at a PM output of 0.01 g/bhp-hr. This is two-thirds of the Tier 4 PM emission limit for the switcher duty cycle (0.03 g/bhp-hr). The switcher experienced minor mechanical problems (not related to the DPF) that resulted in unfavorable utilization during the latter half of 2012. However, the switcher has been repaired in an effort to accumulate the 3,000 hours needed for CARB verification (and before expiration of the CARB's grant term in 2013).

## **2.3 Harbor Craft**

### *2.3.1 Hug Filtersystems Tier 4 Harbor Craft Retrofit*

Under the TAP, Hug Filtersystems (Hug) will be demonstrating the effectiveness of retrofitting an existing harbor craft vessel with an advanced diesel emission control system. In partnership with Sause Brothers, the Hug mobiclean® advanced DPF/SCR system (mobiclean® system) will be installed on the Arapaho, a construction tugboat. This mobiclean® system is a passive-regeneration diesel particulate filter (DPF)/diesel oxidation catalyst (DOC) and selective catalytic reduction (SCR) system expected to reduce total particulate matter (PM) emissions by greater than 70 percent and nitrogen oxide (NOx) emissions by greater than 80 percent.



The Arapaho was repowered in late 2010 and is now equipped with two main propulsion 2010 Tier 2 MTU Detroit Diesel 12V 2000 M60 engines (805 hp, EPA engine family #AMDDN31.8MRR). As part of this TAP demonstration project, Hug will install and monitor two mobiclean® systems on each of the two Tier 2 main propulsion engines.

The objective of this demonstration project is to collect emission test data to submit to CARB in order to obtain Level 3 verification for the mobiclean® advanced DPF/SCR system for a broad range of harbor craft applications. Upon receiving CARB verification, Hug plans to market the mobiclean® system as a Tier 4 emission level upgrade kit for Tier 2 or newer vessel engines.



### *Emission Control Technologies*

The Hug mobiclean® system is designed to be fitted on four-stroke marine engines with a range of 150 to 900 horsepower (hp) and a qualifying high exhaust temperature profile. The Hug mobiclean® advanced DPF/SCR system consists of a soot particle filter, soot regeneration, deNO<sub>x</sub> oxidation, and a control system.

The mobiclean® filter system is based on a ceramic silicon carbide honeycomb structure. The exhaust gases stream through the porous honeycomb walls, which help to retain more than 99 percent of fine particles (20-300 nanometers in size). Figure 2.6 provides an illustration of the Hug system.

**Figure 2.6: Hug mobiclean® Diesel Particulate Filter System**

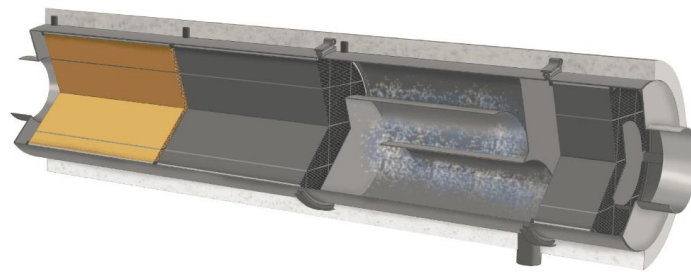

The Hug mobiclean® system utilizes passive regeneration, where particulate matter is continually burned off during vessel operation using a combination of the exhaust heat and a catalyst to facilitate combustion of the soot.

In conjunction with the SCR system, the downstream DeNO<sub>x</sub> oxidation system reduces other pollutants in the exhaust gas, such as NO<sub>x</sub>, CO and hydrocarbon. Standard urea solutions are used as reactants and are injected before the soot filter, which helps to reduce NO<sub>x</sub> in the filter as well as in the downstream SCR-catalytic converter. The control system monitors the pollutants in the exhaust gas and adjusts the volume of urea solution injected, thus automatically adapting to different fuel qualities and pollutants.

**Environmental Benefits**

It is anticipated that the Hug mobiclean® system retrofit will reduce total PM emissions by greater than 70 percent and NOx emissions by greater than 80 percent on Tier 2 four-stroke marine engines. Successful demonstration of these emission reduction levels will allow Tier 2 harbor craft vessels to be retrofitted to meet Tier 4 emission standards. Table 2.4 compares Tier 2 standards to the emissions of engines equipped with the Hug mobiclean® system.

**Table 2.4: Comparison of Tier 2 Expected Emissions with and without Hug Mobiclean®**

Tier 2 Engine Emission Standards	Tier 2 Engine with Hug mobiclean® Tier 4 Retrofit
PM            0.1 g/bhp-hr NOx/HC      6.5 g/bhp-hr	PM   <0.03 g/bhp-hr (>70% reduction from Tier 2) NOx   <1.3 g/bhp-hr (> 80% reduction from Tier 2) HC    <0.14 g/bhp-hr

**Project Partners & Funding**

The total cost of the Hug Tier 4 retrofit demonstration project is \$531,308. Using TAP funds, POLB and POLA each contributed \$132,827, for a total of \$265,654. The TAP funding is budgeted towards installation, emissions testing, reporting, and pursuit of CARB verification. Additionally, the SCAQMD will be contributing \$100,000 in funding toward the project equipment purchase and installation. Hug and their participating vendor support team are covering the balance of project costs in the amount of \$165,654. Sause Brothers is providing one of its construction tug boats, Arapaho, for use in the demonstration, though the value of this contribution is not quantified. Project costs are summarized below in Table 2.5.

**Table 2.5: Hug Filtersystems Tier 4 Retrofit Project Funding Partners**

Project Partners	Contributions
Port of Long Beach	\$132,827
Port of Los Angeles	\$132,827
SCAQMD	\$100,000
Hug Filtersystems	\$165,654

**Project Status**

To date, the demonstration for the Arapaho tug boat has not begun. Originally, the installation of the Hug mobiclean® system was anticipated to occur in spring 2012. However, Hug is currently working on a similar, but separate, demonstration and verification project on a two-stroke marine engine aboard another Sause Brothers’ tug boat, Apache. For this project, Hug is partnering with the SCAQMD under a CARB Air Quality Investment Program grant. TAP staff is tracking the progress of this “sister” project, although no TAP funding is allocated. After completion of the project on the Apache, the TAP project on the Arapaho is anticipated to begin.

The demonstration project for the Arapaho is approximately one year in duration, during which emissions testing and data collection will be conducted to support Hug's application to CARB seeking Level 3 verification. It is anticipated that this project will begin once the SCAQMD sister project is complete.

## 2.4 Cargo Handling Equipment

### 2.4.1 RYPOS Advanced Diesel Particulate Filter for Cargo Handling Equipment (CHE)

Since 2009, RYPOS Inc. (RYPOS) initiated a number of different project demonstrations in an effort to evaluate the effectiveness of their Hybrid Diesel Particulate Filter/Catalyst (HDPF/C™) system in various port equipment applications. These projects include:

- Installation of the HDPF/C™ system on an RTG crane at International Transportation Service, Inc. (ITS) at the Port of Long Beach in 2009;
- Installation of the HDPF/C™ system on a top handler and a side handler at Seaside Transportation Services, LLC (STS) at the Port of Los Angeles in 2010; and
- Installation of the HDPF/C™ system on an RTG crane at STS terminal in early 2011.

The RYPOS HDPF/C™ was originally designed as a passive/active-regeneration diesel particulate filter estimated to reduce particulate matter emissions by more than 85 percent. The system incorporated a microprocessor-controlled, electric heating element to regenerate and burn off accumulated DPM captured by the filter without additional action by the equipment operator. A diesel oxidation catalyst (DOC) attached to the outlet of the particulate filter was used to remove the soluble organic fraction of particulate matter while also reducing hydrocarbon, carbon monoxide, and nitrogen dioxide emissions. Figure 2.7 provides a visual of the DPF location.

**Figure 2.7: The RYPOS HDPF/C™ System Installed on an RTG Crane**



RYPOS redesigned and upgraded the HDPF/C™ for RTG cranes with an all-electric charged, active regeneration filter—the ActiveDPF/C™, with plans to do the same for top and side handler applications. The ActiveDPF/C™ is designed to regenerate at any exhaust temperature and is not affected by idling.

***Emission Control Technologies***

The RYPOS ActiveDPF/C™ system consists of the filter housing, flow control, electrical control circuit, and filter cartridges. The electrical control circuitry automatically monitors and controls the regeneration of the filter cartridges.



The diesel particulate filter cartridge is composed of sintered metal fibers that are shaped into filter elements and then incorporated into filter cartridges. These sintered metal fiber cartridges are capable of capturing the very fine carbon particles present in the exhaust stream, with high efficiency and high holding capacity. The diesel oxidation catalyst filter cartridge reduces CO, NO<sub>2</sub>, and hydrocarbon emissions, and can act as a sound absorption device, replacing the muffler while occupying the same space.

The operation of the RYPOS ActiveDPF/C™ is controlled by a microprocessor. The controller monitors the filters and, as required, an electric current is passed through a filter element, which then acts as a heating element. A dedicated power source provides the required electrical current to heat each filter element individually to the temperature required to burn soot, reducing the maximum amount of electrical energy required. This regeneration strategy is designed to keep the back pressure below a pre-set level. The average power consumption required for regeneration is less than one percent of the rated power of the engine.

***Project Partners & Funding***

The total cost of the RYPOS ActiveDPF/C™ demonstration is \$322,140. Using TAP funds, each Port contributed \$64,668, for a total of approximately 40% of the project cost. The TAP funding is budgeted primarily for emissions testing and receipt of CARB verification. RYPOS and their participating vendor support team are covering the balance of project costs, at \$192,804. Project costs are shown below in Table 2.6.

**Table 2.6: RYPOS ActiveDPF/C Demonstration Funding Partners**

Project Partners	Contributions
Port of Long Beach	\$64,668
Port of Los Angeles	\$64,668
RYPOS	\$192,804

***Environmental Benefits***

In August 2011, the RYPOS ActiveDPF/C™ was verified by CARB to reduce particulate matter in the RTG crane application at CARB Level 2-plus verification (50 percent, but actual test results showed 83 percent reduction effectiveness). RYPOS is working to achieve Level 3 verification for CHE by early 2013.

### *Project Status*

RYPOS' original plans were to simultaneously develop an ActiveDPF/C™ system for use on RTGs and top handlers and side handlers. In early 2012, RYPOS prepared and submitted to CARB an in-use operation test plan for review. During that time, tests conducted on the filter prompted a reevaluation of voltage needed for optimum regeneration as well as filter design and sizing. With much of their time focused on obtaining Level 3 verification for the RTG crane application, RYPOS was unable to allocate enough resources toward the development of the Active DPF/C™ system for the off-road top and side handler applications. Even though RYPOS was not able to achieve DPF verification for these applications, RYPOS was able to achieve Level 2 DPF verification for RTG crane application. This allowed RYPOS to meet one of their obligations under the TAP. The balance of contract funds not expended (\$64,668.42) to complete the project was returned to the TAP budget.

RYPOS is currently pursuing CARB Level 3 verification (at least 85 percent PM reduction) for the Active DPF/C™ system for RTG cranes by adjusting the software that dictates how often regeneration occurs on an RTG crane at TraPac at POLA. This demonstration is being conducted outside the scope of the original TAP contract; however, TAP staff will follow progress and provide status updates of the technology to interested terminal operators.

## **2.5 Container Drayage Trucks**

### *2.5.1 AQMD HDV In-Use Emissions Testing Program*

The Ports joined an existing SCAQMD research program<sup>6</sup> to conduct in-use emissions testing for class 8 diesel- and LNG-fueled trucks, and if needed, to evaluate emission-reduction potential of retrofit technology on existing and new on-road heavy-duty engines. The original project scope was budgeted at a total \$1,701,156. The University of California, Riverside (UCR) and West Virginia University (WVU) were selected by competitive bid to conduct this emissions testing program jointly with SCAQMD. The TAP funding for this project will cover program enhancements to include emissions testing of additional drayage trucks utilizing a newly developed port drive test cycle<sup>7</sup> specifically derived from in-use drayage operation. The TAP will provide \$306,552 in co-funding to test six additional heavy-duty drayage vehicles using the Ports' drive test cycle, bringing the total project budget to \$2,007,708.

---

<sup>6</sup> On December 3, 2010, the SCAQMD Board awarded contracts to the University of California, Riverside (UCR) and West Virginia University (WVU) to conduct in-use emissions testing, and if needed, to evaluate emission-reduction potential of retrofit technology on existing and new on-road heavy-duty engines.

<sup>7</sup> See Section 2.5.4 for more information on this new cycle.

### *Technical Approach*

The objectives of the project include: in-use emissions testing of heavy-duty natural gas and diesel vehicles to verify emissions standards and the emission-reduction potential of engine or aftertreatment technology to reduce regulated emissions over time; measurement of ammonia and formaldehyde emissions from heavy-duty vehicles; the effectiveness of oxidation catalysts or alternative technologies to reduce these emissions; the assessment of the emission-reduction potential of exhaust gas recirculation (EGR) to reduce PM and NO<sub>x</sub> emissions from diesel engines; and the impact of using water in-lieu of urea or no reductant for SCR technology. To achieve these objectives, the project includes on-road heavy-duty vehicles used in transit, school bus, refuse, and goods movement applications and powered by engines fueled with natural gas, propane, diesel, and combination of diesel and natural gas fuels.

The vehicles will be tested across 66 different test configurations. The engines are categorized into eight groups including natural gas engines with three-way catalysts, high pressure direct injection (HPDI) engines with EGR and DPF with or without SCR technology, propane and diesel school bus engines, propane engines certified at or below 0.2 g NO<sub>x</sub>, diesel engines certified at 1.2 g NO<sub>x</sub>, diesel engines certified above 0.2 g NO<sub>x</sub> without SCR technology, and diesel engines certified at or below 0.2g NO<sub>x</sub> with SCR technology. In addition, WVU will use its Transportable Emissions Measurement System (TEMS) and Horiba Portable Emissions Measurement System (PEMS) to measure in-use emissions from a U.S. EPA 2010 compliant heavy-duty diesel truck loaded to approximately 70,000 pounds, while driven from Morgantown WV to Riverside CA. WVU will continuously track all not-to-exceed events, and measure total and non-methane hydrocarbon, NO<sub>x</sub>, CO, CO<sub>2</sub>, NO<sub>2</sub>, nitric oxide, nitrous oxide, PM, and ammonia emissions.

### *Environmental Benefits*

The project supports the effort to better characterize in-use emissions from port drayage truck operation. While this project does not result in actual emission reductions per se, the knowledge base gained from this comprehensive effort will provide the Ports, SCAQMD and other industry stakeholders with a much better understanding of the in-use emissions that result from implementation of advanced alternative fuel and aftertreatment technologies that could potentially be used to further reduce PM emissions from on-road heavy-duty vehicles.

### *Project Partners & Funding*

The Ports are contributing \$306,552 in co-funding to this project for the additional port-specific testing, bringing the total project budget to \$2,007,708. CARB is also providing an in-kind services contribution to support the project, which will include quantification of criteria pollutant emissions using a portable emission measurement system, collection and analysis of exhaust gases for N<sub>2</sub>O emissions, data analysis, and interpretation of emissions test results and measurements.

Table 2.7 summarizes the project funding contributions.

**Table 2.7: AQMD HDV In-Use Emissions Testing Program**

Project Partners	Contributions
Port of Long Beach	\$153,276
Port of Los Angeles	\$153,276
South Coast Air Quality Management District Team	\$1,701,156

*Project Status*

The SCAQMD is the project manager for this program. An MOA between the Ports and SCAQMD was implemented in early 2012 to facilitate Port co-funding of this project and increase the scope to include port-related testing.

Project vehicle testing began in late 2011. Emissions testing for the following 22 (out of 25 planned) project vehicles was completed as of December 31, 2012:

- Three Compressed Natural Gas (CNG)-fueled drayage vehicles
- One CNG-fueled refuse vehicle
- One CNG-fueled transit bus
- Three High Performance Direct Injection natural gas vehicles
- Two school buses (propane and diesel fuel)
- One propane-fueled drayage truck
- Eleven diesel-fueled drayage trucks

*2.5.2 Vision Motor Corp. Hydrogen Fuel Cell Plug-In Hybrid Electric Trucks*

The Vision Motor Corporation (Vision) project was to develop and demonstrate a zero emission hydrogen fuel cell/hybrid-electric drive system in short haul drayage and terminal container movement operations. The project was intended to include the design, development and demonstration of two vehicle types: 1) the Tyrano™ class 8 on-road truck equipped with Vision’s proprietary hydrogen (H2) fuel cell/hybrid electric drive system; and 2) an off-road terminal tractor equipped with a similar zero-emission hybrid drive system. The demonstrations for each vehicle were slated to involve performance testing to validate maximum speed and maximum daily operating range under various payloads and conditions.

Although the Tyrano™ class 8 on-road truck was completed in 2011, the demonstration never began due to difficulties in obtaining a hydrogen fuel source, personnel and administrative changes at Vision, and technical issues with the truck. Additionally, the off-road terminal tractor, or the Zero Emission Terminal Tractor (Zero-TT), was not completed on schedule due largely to Vision’s temporary loss of a manufacturing facility and a change in the chosen vehicle chassis from Capacity to Cargotec. Both projects were nearly 18 months behind schedule at the end of 2012. Vision’s TAP contract expired December 31, 2012, without extension; as a result, these projects are no longer active. Vision, however, continues to develop and test the Tyrano and Zero-TT, and the Tap staff will continue to monitor the technology’s progress.

### *Emission Control Technologies*

The Class 8 truck is powered by a battery electric drive system that incorporates a hydrogen fuel cell range extender. The design specifications include an estimated 8-hour shift with a range of 200 miles, a governed maximum highway speed of 65 miles per hour, and ability to haul an 80,000 pound payload.



Vehicle System Specifications for the Vision TYRANO™ include the following:

- Vehicle Chassis: Freightliner Cascadia class 8 chassis or equivalent, equipped with air conditioning and heater/defroster;
- Fuel Cell: Hydrogenics Corporation hydrogen fuel cell with two (2) year/5,000 hour extended warranty or equivalent;
- Drive System: Vision Motor Corp. proprietary TYRANO™ hydrogen fuel cell/plug-in electric hybrid drive system;

Performance specifications for the TYRANO™ class 8 on-road truck include:

- Range: 200 miles over an eight (8) hour duration;
- Top Speed: Electronically governed at 65 mph at 80,000 pounds gross combined vehicle weight rating (GCVWR);
- Acceleration: Zero to 15 mph in less than or equal to twelve (12) seconds at 80,000 pounds GCVWR;
- Capacity: 80,000 pound maximum GCVWR;
- Gradeability: Forty (40) mph sustained at 6% grade with vehicle at maximum GCVWR;
- H2 Refueling Time: Average demonstrated refueling time of four (4) to seven (7) minutes;
- Operating Limits: Ambient temperature limits of -15 degrees Fahrenheit to +110 degrees Fahrenheit;
- Horsepower: 402 peak hp;
- Torque: 3,200 pound-feet electronically limited.

Vision intends to complete the design, development, and integration of a Hydrogen Fuel Cell/Plug-in Electric Hybrid Drive Zero Emission Terminal Tractor (Zero-TT) in 2013 in cooperation with its private partners. The Zero-TT will be designed for container movement operations at a terminal yard.



Vehicle System Specifications for the Zero-TT are expected to include the following:

- Vehicle Chassis: Cargotec terminal tractor;
- Fuel Cell: Hydrogenics Corporation hydrogen fuel cell with two (2) year/5,000 hour extended warranty or equivalent;
- Drive System: Vision Motor Corp. proprietary hydrogen fuel cell/plug-in electric hybrid drive system.

The Zero-TT will have the following minimum performance specifications:

- Range: 100 miles over an eight (8) hour duration;
- Capacity: 130,000 pound maximum GCWWR;
- H2 Refueling Time: Average demonstrated refueling time of four (4) to seven (7) minutes;
- Operating Limits: Ambient temperature limits of -15 degrees Fahrenheit to +110 degrees Fahrenheit;
- Horsepower: 402 peak hp;
- Torque: 3,200 pound-feet electronically limited.

### *Project Partners & Funding*

The Hydrogen Fuel Cell Heavy-Duty Class 8 Short Haul Truck and Zero-Emission Terminal Tractor Demonstration were budgeted for \$999,211 with \$425,000 provided by POLB and POLA and \$574,211 from Vision as matching funds. The Ports expended \$191,250 (\$95,625 per Port) for the completion of the Tyrano drayage truck, prior to the expiration of the project contract. The unspent funds will return to the TAP Fund for future allocation on other projects.

### *Environmental Benefits*

Zero-emission vehicles (ZEVs) provide significant environmental benefits. Tailpipe emissions are completely eliminated, and even on a lifecycle basis (i.e., including the fuel cycle emissions of hydrogen versus petroleum diesel fuel production and distribution), the ZEVs are cleaner than conventional alternatives. Successful completion of this project will directly support the joint Port effort to increase the use of zero-emission technology in port equipment. This effort is detailed<sup>8</sup> in the Ports' "Roadmap for Moving Forward with Zero Emission Technologies at the Ports of Long Beach and Los Angeles."

### *Project Status*

On July 22, 2011, the Tyrano™ class 8 was delivered to Total Terminal Services, Inc. (TTSI). Vision and TTSI conducted some preliminary tests of the Tryano™. There were delays in initiating the formal project demonstration due to difficulty with securing a hydrogen fuel source and to technical issues that arose with the Tyrano's converter. Similarly, the Zero-TT project experienced a wide range of delays.

Due to the numerous delays encountered on these projects in 2011 and to the continuing delays in 2012, the Vision TAP contract expired in December 2012 prior to completion of the project.

---

<sup>8</sup> This report can be downloaded from <http://www.cleanairactionplan.org/reports/default.asp>

### 3.0 WITHDRAWN PROJECTS

On occasion, there are approved projects that cannot be carried out to completion. This occurred in the case of one TAP project during 2012, as discussed below.

In late 2012, Artisan Vehicle Systems (Artisan) notified the TAP that they were withdrawing from their TAP project that would have demonstrated a Class 8 drayage all-electric, zero emission truck (model name GP8e), specifically designed for short-haul drive cycles. Artisan indicated a need to focus on their core business of manufacturing powertrain systems for various motor vehicle applications, which did not leave ample time for development projects. Funding that was previously allocated for this project was returned to the TAP budget.



#### 4.0 ADDITIONAL PORT-RELATED ADVANCED TECHNOLOGY EFFORTS

The TAP tracks other related efforts that support the overall TAP goals and mission. Currently, there are two major Port initiatives underway that synergistically support the TAP mission. These include the Zero-Emission Technology Development Program and the implementation of 2010 CAAP Update Measures OGV-5 and OGV-6.

##### *Zero-Emission Technology Development Program*

The mission statement for the Ports' TAP is "...to accelerate the verification or commercial availability of new, clean technologies, through evaluation and demonstration, to move towards an emissions-free port." As summarized above in Section 2, the TAP is currently evaluating and demonstrating technologies that could eventually lead to deployment of zero-emission technologies for sources in port-related operations. Some of those technologies represent interim or transitional technologies that help to significantly reduce air emissions, but are not yet emissions-free. Nonetheless, the deployment of these technologies in the near term will help ports reduce air emissions and associated health risks while continuing to strive for full deployment of zero-emission technologies in the appropriate areas of port goods movement for the future.

In July 2011, the Ports' Harbor Commissions met jointly to consider the staff report<sup>9</sup> entitled "Roadmap for Moving Forward with Zero Emission Technologies at the Ports of Long Beach and Los Angeles." An outcome of this meeting was to direct staff to expand the TAP guidelines to allow for consideration and potential funding of early stage zero-emission technology projects. This expansion is necessary since the TAP is currently focused on near-term technologies that are ready for commercial deployment following an in-use demonstration in the port environment. An expansion of the guidelines facilitates the opportunity for promising, early stage technologies to potentially participate in the TAP.

##### *2010 CAAP Update Measures OGV-5 & OGV-6*

Ships remain the San Pedro Bay's biggest contributor to poor air quality. As indicated by the Ports' respective 2011 Emissions Inventories, OGVs account for approximately 61 percent of the port-related diesel particulate matter, 54 percent of NO<sub>x</sub> emissions, and almost all of SO<sub>x</sub> emissions. As such, the 2010 CAAP Update called for a two-pronged approach to clean up the San Pedro Bay shipping fleet: (1) attract newly built ships that meet the most up-to-date, strictest environmental standards, and (2) reduce emissions in the legacy fleet through retrofit technologies or operational changes. The CAAP identifies these efforts as control measures OGV-5 and OGV-6 respectively.

In 2012, consistent with the goals of OGV-5, both Ports adopted incentive programs targeted at attracting the cleanest vessels. Under the direction of OGV-6, the Ports have also been identifying promising emission-reduction technologies for OGVs, which will be demonstrated through the TAP to determine their effectiveness in the real-world operating conditions in San Pedro Bay.

---

<sup>9</sup> This report can be downloaded from <http://www.cleanairactionplan.org/reports/default.asp>

The Ports convened an Industry Working Group to raise awareness of OGV-6 and to solicit partners for future TAP demonstrations of marine technologies. Additionally, the Ports formed a Regulatory Working Group comprised of U.S. EPA, CARB and SCAQMD to discuss the challenges and opportunities in advancing OGV emission reduction technologies. Because many OGV emission reduction technologies do not fit under traditional verification protocol, the Regulatory Working Group developed an alternative approach, the Regulatory Framework. The Regulatory Framework details the process to document the emission reductions from OGV technologies outside of the traditional non-OGV related technology verification process. In addition, the Ports released an initial version of the “San Pedro Bay Ports Emission Reduction Strategy Guide,” which provides details on promising OGV technologies as a resource for regulatory agencies and shipping lines. Additionally, the Ports worked with CARB to develop emissions testing guidelines so Ports and regulatory agencies can agree on the emission reductions from OGV technologies that reduce NO<sub>x</sub>, DPM and SO<sub>x</sub>. This CARB publication is entitled “Recommended Emissions Testing Guidelines for Ocean-going Vessels (Version 1, June 20, 2012).”<sup>10</sup>

#### *OGV-5 & OGV-6 Incentives*

Effective July 1, 2012, the Port of Los Angeles began offering multiple incentives for less polluting ships following the protocol established by the International Association of Harbors and Ports, Environmental Ship Index Incentive Program, as well as incentives for ship main engines meeting the IMO NO<sub>x</sub> Tier II and Tier III standards. Ships can obtain additional incentives by having new builds that meet the standard or being equipped with engine reduction technologies. This voluntary incentive program rewards vessel operators for reducing DPM, NO<sub>x</sub>, and SO<sub>x</sub> in advance of, and beyond, regulations.

Also effective July 1, 2012, Port of Long Beach’s Green Ship Incentive Program began providing incentives for ship main engines meeting the IMO NO<sub>x</sub> Tier II and Tier III standards. This voluntary incentive program rewards vessel operators for reducing NO<sub>x</sub>, and SO<sub>x</sub> in advance of regulations.

#### *Additional Technology Advancement Efforts Tracked by TAP*

In addition to the above major initiatives, there are a number of other TAP-related efforts being tracked by the TAP. These include:

- The Port of Long Beach released a Request for Information (RFI) in late 2010 for at-berth emission reduction technologies. Fifteen responses were received; these served as the basis for the development of a Request for Proposals (RFP), which was later released in December, 2011. ACTI’s Advanced Maritime Emissions Control System (AMECS) was preliminarily selected for a demonstration; contract negotiations are still underway. POLB anticipates taking the project to their Board of Harbor Commissioners for consideration in 2013.

---

<sup>10</sup> <http://www.arb.ca.gov/ports/marinevess/ogv/ogvreports.htm>

## San Pedro Bay Ports Technology Advancement Program 2012 Annual Report

- In June 2010, CARB awarded \$1 million via competitive solicitation to the POLB to fund the demonstration of Foss Maritime's hybrid retrofit technology to reduce emissions from marine vessels by converting an existing diesel tugboat to operate with a hybrid engine. The hybrid engine has the potential to reduce NOx emissions by 50 percent and fuel use by 20 percent compared to a conventional diesel engine. This project supports CARB's goals of demonstrating hybrid technology in off-road applications and providing an alternative compliance mechanism for CARB's harbor craft regulation. The tugboat project completed operational testing at the Ports of Long Beach and Los Angeles in the fall of 2012, with the final report expected in early 2013. The converted tugboat is expected to remain in service at the Ports beyond the scheduled demonstration period, and the technology provider intends to formally validate the emission reductions in order to allow these types of projects to be qualify for funding through the Carl Moyer Program and other grant programs.
- Hug Filtersystems is working on a demonstration and verification project to demonstrate a combined diesel particulate filter and selective catalytic reduction technology on 2-stroke marine vessel engines at a cost not to exceed \$396,580. This project is being funded by the SCAQMD under a CARB Air Quality Investment Program grant and is similar in scope to the TAP project as described in Section 2.3.1. The technology will be installed on the Sause Brothers construction tugboat, Apache. The primary difference between the two projects is that the TAP project's demonstration engine is 4-stroke while the SCAQMD project's demonstration engine is 2-stroke.
- Port staff is tracking the status of the efforts resulting from the continued demonstration of the hybrid drive technology developed by US Hybrid for use in Kalmar Ottawa yard hostlers in a separate, but parallel, project conducted by the New York Power Authority and the Port Authority of New York/New Jersey. Three of the newer generation hybrid yard hostlers have been operating in day-to-day terminal operations at New York Container Terminal since 2010. Similar to the TAP project conducted at LBCT, the hybrid vehicles' in-use performance and fuel economy are being assessed. In addition, chassis dynamometer emissions testing will be conducted.
- Following the demonstration of Capacity of Texas' (Capacity) Plug-in Hybrid Terminal Tractor (PHETT) at POLB and POLA, Capacity has marketed the PHETT in various applications throughout the U.S. and internationally. However, because the PHETT utilizes a Tier 4-interim generator drive engine (genset), it does not meet the requirements for port yard tractors in California under CARB's Cargo Handling Equipment regulation, which requires engines meeting Tier 4 final off-road or 2007 on-road emissions standards. Capacity has since focused their efforts on the development of a zero-emissions terminal tractor, the ZETT, powered by plug-in electric/hydrogen fuel cell technology.

- The SCAQMD and Volvo Technology of America, Inc. have partnered to develop and demonstrate a Class 8 plug-in, hybrid-electric, Class 8 drayage truck. The power and torque capabilities of the hybrid system will allow the combustion engine to be significantly downsized. The preliminary design includes the capability to operate in 100% all-electric mode (via stored energy from the battery pack), which would be targeted for in-port operation. The plug-in propulsion system might also be connected to a wayside power supply in the future though this is not a feature of the current project. The total project cost is estimated to be \$2.4 million. Volvo estimates that NOx and PM will be reduced 40 and 50 percent per mile, respectively. All tailpipe emissions would be eliminated when the truck is operating in all-electric mode. SCAQMD project management staff attended a project kickoff meeting December 6, 2012. The initial prototype is expected to be complete fourth quarter 2014.
- In May 2012, the SCAQMD, on behalf of the Countywide Zero-Emission Truck Collaborative, applied for a grant from the Department of Energy (DOE). DOE awarded the SCAQMD \$4.1 million for the demonstration which includes 13 zero emission trucks from four vendors as follows: 3 from Balqon, 4 from Vision, 4 from Transpower, and 2 from US Hybrid. The SCAQMD is currently finalizing subcontracts with the four vendors. The vendors will have one year to build the trucks and two years for demonstration and testing. The Ports will be providing technical support and guidance.



## 5.0 2012 TAP BUDGET

The TAP is supported by both Ports as an element of the CAAP at an annual level of \$1,500,000 from each Port (\$3 million total). Additional funding is contributed on an ad-hoc basis by participating agencies, including but not limited to the SCAQMD, CARB, U.S. EPA, and California Energy Commission (CEC). Project co-funding is also contributed by the project proponent as either cash or in-kind contribution, or a combination of both.

The Ports and agency stakeholder investments for all past and current TAP projects approved to date are shown in Table 5.1, below. One project was funded by the TAP in 2012; indicated in bold type within the table. Contributions from participating agencies other than the Ports are typically made on a project-by-project basis. In addition to the funding amounts reflected in Table 5.1, TAP contractors are required to provide a minimum of 50 percent co-funding in the form of cash and/or in-kind contributions to each project. Required match contributions are not included in Table 5.1, but are noted within each project summary in Section 2.



San Pedro Bay Ports Technology Advancement Program  
2012 Annual Report

**Table 5.1: TAP Funding Commitments through December 31, 2012**

Project Category	POLB	POLA	AQMD	CARB	U.S. EPA	CEC	Total Port & Agency Stakeholder
<b><u>Ocean Going Vessels</u></b>							
APL Singapore Slide Valve/WiFE	\$22,500	\$22,500		\$783,628			\$828,628
ACTI AMECS Emissions Testing	\$149,527	\$149,527	\$55,000				\$354,054
Bluefield Holdings Krystallon OGV Scrubber	\$825,000	\$825,000					\$1,650,000
<b>OGV Slide Valve Low-Load Emissions Evaluation</b>	<b>\$108,000</b>	<b>\$108,000</b>					<b>\$216,000</b>
<b><u>Harbor Craft</u></b>							
Foss Maritime Hybrid Tugboat	\$500,000	\$889,920*					\$1,389,920
Hug Filtersystems Tier 4 Tugboat Retrofit	\$132,827	\$132,827					\$265,654
<b><u>Cargo Handling Equipment</u></b>							
LNG Yard Tractor	\$350,000				\$75,000**		\$425,000
Balqon Electric Terminal Tractor		\$263,500	\$263,500				\$527,000
Vycon RTG REGEN Flywheel	\$11,500	\$11,500	\$8,000				\$31,000
Balqon Lithium Battery Upgrade		\$400,000					\$400,000
Hybrid Yard Tractor	\$300,000*	\$300,000*			\$300,000**		\$900,000
LBCT Eco-Crane	\$42,467.50	\$42,467.50		\$130,130			\$215,065
Capacity Plug-In Hybrid Tractor	\$29,500*	\$32,000*					\$61,500
APT Emulsified Biodiesel	\$44,000	\$44,000					\$88,000
<i>RYPOS Diesel Emission Control</i>	<i>\$32,334.21</i>	<i>\$32,334.21</i>					<i>\$64,668.42</i>
Hybrid Yard Tractor Development & Demonstration – Beta Test	\$13,000*	\$13,000*					\$26,000
<b><u>Container Drayage Trucks</u></b>							
<i>Vision Motor Corp. Hydrogen Fuel Cell Plug-In Hybrid Electric Truck</i>	<i>\$95,625</i>	<i>\$95,625</i>					<i>\$191,250</i>
Westport ISX LNG Engine	\$250,000	\$250,000	\$1,250,000			\$500,000	\$2,250,000
SoCalGas CNG Drayage Truck	\$111,577.50	\$111,577.50	\$421,250				\$644,405
<b><u>Locomotives</u></b>							
Johnson Matthey DPF Locomotive Demonstration	\$75,000	\$75,000		\$346,178			\$496,178
<b><u>Research Projects</u></b>							
Heavy-Duty Drayage Truck Duty Cycle Characterization	\$12,681*	\$13,000*					\$25,681
Development of Drayage Truck Chassis Dynamometer Test Cycle	\$12,000*	\$11,466*					\$23,466
AQMD HDV In-Use Emissions Testing Program	\$153,276	\$153,276	\$1,701,156				\$2,007,708
Total Investment	\$3,270,815.21	\$3,976,520.21	\$3,698,906	\$1,259,936	\$375,000	\$500,000	\$13,081,177.42
Total TAP Investment	\$2,903,634.21	\$2,717,134.21					
<b>Total Ports' TAP Investment</b>	<b>\$5,620,768.42</b>						

\*This funding amount is a non-TAP, Port funding contribution to the project.

\*\*Denotes EPA-grant funding contribution from the U.S. EPA West Coast Collaborative (pre-dating the TAP).

"*Italics*" denotes projects that were modified during implementation in a manner that changed the original budget. See Section 2 for more information.



## 6.0 TAP PRIORITIES FOR 2013

The TAP Priorities for 2013 will continue to support the Zero-Emission Technology Development Program and the implementation of 2010 CAAP Update ship measure OGV-6.

In addition, the TAP will continue to support the identification, development and demonstration, and, ultimately, CARB verification of lower emitting technologies applicable to all source categories and focus areas identified in the CAAP. Therefore, the TAP funding priorities for 2013 will be based on the technology needs identified in the 2010 CAAP Update to improve air quality at the Ports and protect the health of residents of the South Coast Air Basin. The technical and programmatic TAP priorities for 2013 are summarized below.

### *2013 Technical Priorities:*

For 2013, the Ports will continue the effort to identify and develop TAP technologies for the key source categories that contribute to port emissions. This includes targeting emission reductions from ocean-going vessels, locomotives, on-road and off-road trucks with continued focus on zero or near-zero emission technologies.

### *2013 Programmatic/Policy Priorities:*

For 2013, a number of program enhancements continue to be pursued, including:

- Working to identify opportunities to further integrate port operators and other stakeholders into the technology review process, with the goal of facilitating acceptance into port operations following demonstration. This will support both the zero-emission technology and OGV-6 efforts;
- Facilitating “matching” potential fleets with technology companies to reduce the difficulty some companies encounter when trying to find a project partner;
- Focusing on providing additional support to TAP contractors to better navigate CARB’s verification process to minimize the time between concept and commercial application;
- Increasing coordination and the level of communication with other domestic and world ports as it relates to air quality improvement technologies and the potential for inclusion in the CAAP;
- Partnering with the TAP Advisory Committee member agencies, other agency stakeholders, and project proponents in an effort to leverage TAP funding and maximize the effectiveness of the TAP;
- Ensuring that port equipment operators are aware of grant program eligibility, and when appropriate, facilitate application to such programs, which include, but are not limited to, the U.S. EPA Emerging Technologies Program, CARB’s AB 118 Air Quality Investment Program, and SCAQMD’s Carl Moyer Program.

APPENDIX A

TECHNOLOGY ADVANCEMENT PROGRAM ADVISORY COMMITTEE MEMBERSHIP

- Dr. Randall Pasek, South Coast AQMD rpasek@aqmd.gov
- Dipankar Sarkar, South Coast AQMD dsarkar@aqmd.gov
- John Lee, California Air Resources Board jlee@arb.ca.gov
- Roxanne Johnson, U.S. EPA Region 9 johnson.roxanne@epa.gov

TECHNOLOGY ADVANCEMENT PROGRAM STAFF

**Port of Long Beach**

925 Harbor Plaza  
Long Beach, CA 90802

**POLB Technology Advancement Program Staff**

- Rose Siengsubcharti, POLB TAP Coordinator sieng@polb.com
- Heather Tomley, Asst. Director of Environmental Planning tomley@polb.com
- Allyson Teramoto, Environmental Specialist teramoto@polb.com
- Janna Watanabe, Environmental Specialist Associate watanabe@polb.com
- Renee Moilanen, Environmental Specialist Associate moilanen@polb.com

**Port of Los Angeles**

425 S. Palos Verdes Street  
San Pedro, CA 90731

**POLA Technology Advancement Program Staff**

- Teresa Pisano, POLA TAP Coordinator tpisano@pola.org
- Kevin Maggay, Air Quality Supervisor kmaggay@pola.org
- Lisa Wunder, Assistant Air Quality Supervisor lwunder@portla.org
- Carter Atkins, Environmental Specialist catkins@portla.org
- René Spencer, Environmental Specialist rspencer@portla.org

**Administrative & Technical Support Staff**

- Ray Gorski, Starcrest Consulting Group, LLC rgorski@starcrestllc.com
- Lauren Dunlap, Starcrest Consulting Group, LLC ldunlap@starcrestllc.com

## Appendix B

### Summary Reports for Past Projects

The following Technology Advancement Program projects are concluded or completed:

1. ACTI Advanced Maritime Emission Control System (AMECS) Project (2008)
2. APL Singapore Slide Valve & Water-In-Fuel Emulsion Demonstration Program (2009)
3. Alternative Petroleum Technologies' Emulsified Biodiesel (2011)
4. Balqon E-30 Electric Terminal Tractor Development & Demonstration Project (2009)
5. Balqon Lithium-Ion Battery Demonstration (2011)
6. Capacity Plug-In Hybrid Electric Terminal Tractor (2010)
7. Characterization of Drayage Truck Duty-Cycles (2011)
8. Development of a Drayage Truck Chassis Dynamometer Test Cycle (2011)
9. Foss Maritime Green Assist™ Hybrid Tugboat (2010)
10. Hybrid Yard Tractor Development & Demonstration (2010)
11. Hybrid Yard Tractor Development & Demonstration – Beta Test (2011)
12. Liquefied Natural Gas Yard Tractor Demonstration (2007)
13. Long Beach Container Terminal Eco-Crane™ (2011)
14. RYPOS Advanced Diesel Particulate Filter for Cargo Handling Equipment (2012)
15. SoCalGas CNG Drayage Truck Demonstration (2010)
16. Vision Motor Corp. Hydrogen Fuel Cell Hybrid Electric Trucks (Zero-TT and Tyrano) (2012)
17. VYCON REGEN® System for Rubber-Tired Gantry Cranes Testing & Verification (2007)
18. Westport GX LNG Engine Development (2010)

Summaries of the Final Reports submitted for these projects are included herein. Final reports are available for download at <http://www.cleanairactionplan.org/programs/tap/techdemos.asp>

## ACTI Advanced Maritime Emission Control System

### Technology Manufacturer

Advanced Cleanup Technologies, Inc. (ACTI)

### Co-Participants

Port of Long Beach, Port of Los Angeles, South Coast Air Quality Management District, Metropolitan Stevedore Company, Engine Fuel & Emissions Engineering, Inc., Professional Environmental Services

### Background

Advanced Cleanup Technologies, Inc. (ACTI) is a professional full service firm specializing in environmental emergency response, hazardous waste cleanup, and air pollution control technology. ACTI developed the Advanced Maritime Emissions Control System, or AMECS, as an alternative pollution control method for ocean-going vessels that are not configured to use shore power, also known as “cold ironing”, while at berth.

### Project Objective

To investigate the technical and commercial feasibility of reducing emissions from ocean-going vessels not configured to use shore power while at berth. The goal was to demonstrate pollution reduction efficiencies equal to cold ironing for nitrogen oxides (NO<sub>x</sub>), sulfur oxides (SO<sub>x</sub>), and particulate matter (PM).

### Technology Demonstration

The AMECS design tested during the demonstration used a shroud lifted over the vessel exhaust stack by means of a specially designed crane and deployment arm. The shroud was then lowered over the stack and then cinched to provide a soft attachment between the shroud and the ship's stack.

A seal closes the open area between the perimeters of the bonnet and ship's stack to limit the amount of air entering the bonnet as well as to prevent exhaust gases from escaping. The exhaust gases from the ship's auxiliary engines and the boilers are routed through a flexible duct to an Emission Treatment System (ETS) located on the dock adjacent to the vessel's berth. The ETS uses multiple exhaust gas treatment technologies to remove both gaseous and particulate pollution:



The **Pre-Conditioning Chamber (PCC)**, which uses a counter-flow spray system to remove PM and water soluble organic gases. The spray water is treated with sodium hydroxide to simultaneously remove sulfur oxide pollution. The water spray also cools the exhaust gas, allowing smaller particles to coalesce such that they are more efficiently captured in subsequent phases of exhaust gas treatment;

**Cloud Chamber Scrubbers (CCS)** remove the remaining exhaust PM. Three separate units generate a fog of very fine water droplets with a high electrical charge. The charged water droplets attract and capture multiple PM particles. The PM laden water is circulated through filters where the PM is removed. The three cloud chambers are identical except for the polarity of the charge imparted to the water droplets. Sodium hydroxide is also injected into the water streams of the cloud chambers to remove any remaining sulfur oxides;

**Selective Catalytic Reduction (SCR) Reactor** removes  $\text{NO}_x$  emissions. Liquid urea is injected into the hot gas stream ahead of the SCR where it is converted to ammonia. The ammonia reacts with the  $\text{NO}_x$  while passing through the catalyst to form nitrogen and water vapor, which are then vented to atmosphere. The SCR Reactor is designed to remove at least 99% of the  $\text{NO}_x$  emitted by the vessel while at berth;

The **Continuous Emissions Monitoring System (CEMS)** is used to measure exhaust gas pollution levels both into and out of the ETS. This system is used to gauge pollutant removal efficiency, as well as control the injection rates of sodium hydroxide and urea used during exhaust treatment.

#### Status

The TAP-sponsored AMECS demonstration and testing project was completed as of July, 2008. The Final Report documenting the test protocols and measured emission reduction efficiency levels was prepared by TIAX LLC on behalf of ACTI and submitted to the Ports and South Coast AQMD for review and comment. The demonstration results were also provided to and underwent an independent evaluation by the California Air Resources Board (CARB). As a result of their evaluation, CARB submitted a letter on December 15, 2008, stating their concurrence with the AMECS emissions efficiency testing results.

#### Results

The AMECS was demonstrated at Metropolitan Stevedore/Port of Long Beach on multiple vessels with varying exhaust stack configurations. During the demonstration period, two full-scale emission reduction efficiency tests were conducted, the results of which were independently verified by two testing laboratories.

#### Benefits

During emissions testing,  $\text{NO}_x$  and PM emissions were reduced by 99% and 95.5%, respectively. In addition, sulfur oxides ( $\text{SO}_x$ ) were reduced by 99%, and volatile organic compound (VOC) emissions were reduced by greater than 97 percent.

#### Project Costs

The total project cost was \$603,211. Funding included \$149,527 from each Port's TAP budget and a \$55,000 contribution from the South Coast AQMD.

### Commercialization and Applications

Further demonstration of this technology is necessary to determine how it functions in day-to-day operations, including evaluation of costs, durability, integration into operations, etc. ACTI is conducting additional testing with SCAQMD, using a grant from EPA. At the conclusion of the demonstration, the system should secure validation of the emission performance from EPA and CARB, which can clear the way for future commercialization of the technology.



## APL Singapore Slide Valve & Water-In-Fuel Emulsion Demonstration Project

### Technology Manufacturer

MAN B&W Diesel  
Sea to Sky Pollution Solutions

### Co-Participants

Port of Long Beach, Port of Los Angeles, University of California-Riverside CE-CERT, Bay Area AQMD, Ventura County APCD, San Luis Obispo County APCD, Santa Barbara County APCD, California Air Resources Board, U.S. EPA Region 9



### Background

The Technology Advancement Program completed participation in a demonstration of emission reduction technologies aboard the container ship *APL Singapore*. Two emission control technologies were demonstrated - the use of slide valves in the vessel's main engines, and water-emulsified bunker fuel using an innovative onboard water in fuel emulsifier.

### Project Objective

To investigate the technical feasibility, engineering requirements, and potential for replication in other ocean going-vessels (OGVs), the San Pedro Bay Ports partnered with the U.S. EPA, CARB, and a number of air districts to demonstrate two retrofit technologies that have the potential to significantly reduce both particulate matter and oxides of nitrogen (NO<sub>x</sub>) emissions. The primary objectives of the demonstration project were to:

- Evaluate the particulate matter (PM) emission reduction effectiveness of retrofitting OGV main engines with an improved injector design known as a slide valve;
- Demonstrate demand-based onboard water in fuel emulsification system and measure the NO<sub>x</sub> reduction effectiveness of varying the water content.

### Technology Demonstration

**Slide Valve Injectors** – Slide valves installed on the APL Singapore's main engine differ from conventional valves in their spray patterns and are designed to reduce dripping of fuel from the injector during the combustion process. Particulate matter is a product of incomplete combustion and unburned fuel. Optimization of the fuel injection system was expected to result in a reduction in fuel consumption and a reduction of PM emissions on the order of 10% to 25%. The slide valve technology was provided by MAN B&W Diesel (MAN).

**Water-in-Fuel Emulsification (WiFE)** – WiFE is the process of introducing water into fuel prior to injection into the combustion cylinder. The fuel-water emulsion technology was provided by Sea to Sky Pollution Solutions. A fuel homogenizer was installed in the APL Singapore’s engine room to produce the emulsification. Fuel and water are carried by separate lines into a mixing chamber called a “homogenizer/emulsifier” which is essentially a large funnel. Inside the funnel is a rotor that spins with a very small clearance next to the funnel’s walls. The spinning rotor draws in the fuel and water, mixes them together and squeezes the mixture out of the funnel with water present in the fuel as tiny droplets. The water droplets, as small as one micron (0.000001 meter in diameter) are fully contained within the fuel.

The fuel/water mixture is immediately injected and atomized within the engine’s combustion chamber. The heat inside the combustion chamber causes the water droplets to vaporize into steam – this requires energy from the combustion process and results in lower peak combustion temperatures. The lower combustion temperatures reduce NO<sub>x</sub> formation.

### Status

The first emissions tests were conducted during a 15-day transpacific voyage from Kaohsiung Taiwan to the San Pedro harbor. Testing was conducted in parallel by University of California-Riverside and MAN B&W. A second test protocol was performed in spring 2008, also conducted by the University of California-Riverside in cooperation with engine manufacturer MAN B&W Diesel.

### Results

Project test conditions resulted in an evaluation that indicated the benefits of slide valves appear to be limited. Emissions testing data were inconclusive and a clear determination of the technology benefits could not be made. Due to the importance of reducing emissions from OGVs, further study is being considered to gain more data and experience with slide valves as a potential emission reduction strategy.

Testing of the WiFE system aboard the APL Singapore yielded the results shown below in the figure below. As shown, water concentrations as high as 48% were successfully demonstrated, yielding NO<sub>x</sub> reductions on the order of 30%<sup>11</sup>.

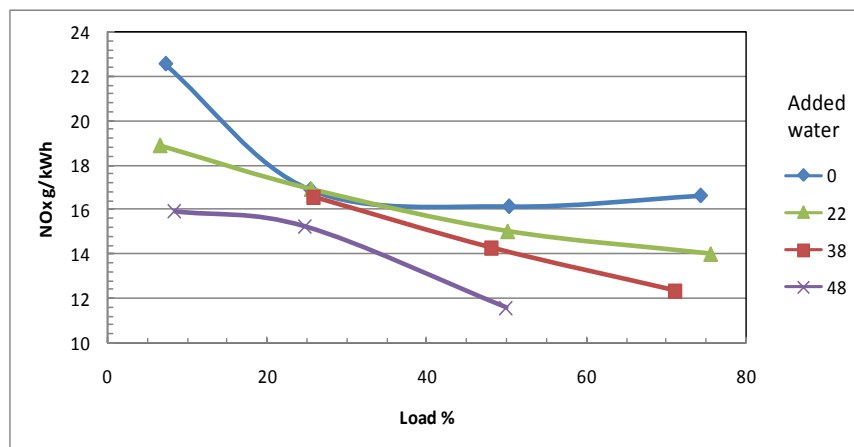

<sup>11</sup> Measurement uncertainty ranges from 3% to 15% for these results.



### Project Costs

Seven funding partners contributed approximately \$1.3 million toward this demonstration and evaluation project. The San Pedro Bay Ports, the Bay Area, Ventura County, San Luis Obispo County, and Santa Barbara County Air Pollution Control Districts contributed funds towards the emissions testing element of the project. The San Pedro Bay Ports contributed \$45,000 in TAP funding toward emissions testing.

### Looking Forward

This project demonstrated the potential for NO<sub>x</sub> reductions that can be achieved through OGV retrofit using commercially available emulsification technology. The Ports are considering additional research to further evaluate the potential for OGV engine emission reductions from the use of slide valves. Engine designers (i.e., MAN and Wärtsilä) are working to meet/exceed customer need for reduced emissions and enhanced fuel economy. Slide valves are one of the many strategies being considered in this regard.



## Alternative Petroleum Technologies Emulsified Biodiesel Fuel Demonstration

### Technology Manufacturer

Alternative Petroleum Technologies, Inc.

### Co-Participants

Port of Long Beach, Port of Los Angeles, West Basin Container Terminal (Ports America)



### Background

The use of biodiesel fuel blends as a method to reduce diesel particulate matter (DPM) and greenhouse gas (GHG) emissions from diesel engines has been studied extensively. The results consistently show that while biodiesel fuels produced from renewable sources have the potential to effectively reduce hydrocarbon, carbon monoxide (CO), and DPM emissions, there is often a corresponding increase in oxides of nitrogen (NO<sub>x</sub>) emissions on the order of 2 percent or greater. Given the serious nonattainment status for ozone in the South Coast Air Basin, any air pollution reduction strategy that increases NO<sub>x</sub> emissions, a principal ozone precursor, is not recommended by state and local air quality regulatory agencies.

### Project Objective

Under the TAP, Alternative Petroleum Technologies, Inc. (APT) set out to demonstrate that their soy-derived, emulsified fuel technology could mitigate the NO<sub>x</sub> emissions increase that is historically associated with the use of traditional biodiesel fuels. The TAP project consisted of both laboratory-based emissions testing and an in-use, field demonstration of the fuel in standard cargo handling activities at the West Basin Container Terminal.

### Technology Demonstration

To demonstrate the viability and effectiveness of the emulsified biodiesel fuel in cargo handling equipment, APT performed a two-phased demonstration that consisted of an evaluation of the emulsified fuel with and without a diesel oxidation catalyst (DOC) in a laboratory setting and a real-time demonstration of the fuel in yard equipment at a port terminal.

The first phase of the project was conducted at Olson EcoLogic Engine Testing Laboratories. Emissions testing was conducted on a 2004 Cummins QSM 11C engine certified to Tier 2 standards, since it is representative of the engines installed in the top handler units featured in the field evaluations. The QSM 11 C is rated at 330hp at 2100 rpm. The engine was tested according to the non-road transient cycle, a standardized engine dynamometer transient driving schedule.

In the second project phase, a field trial was conducted at Ports America, which operated three 2008 model year top handlers in regular container movement operation for a period of five months. Three primary activities constituted the in-use demonstration phase:

1. Operation of three top-handler units on regular B20 biodiesel fuel;
2. Operation of three top-handler units on emulsified B20 biodiesel fuel;
3. Operation of one top-handler unit on emulsified B20 biodiesel fuel with a DOC.

### Status

The APT demonstration project was completed in August 2011 and the final report is available on the TAP website<sup>12</sup>.

### Results

The APT demonstration successfully proved that APT's emulsified B-20 blend mitigated an increase in NO<sub>x</sub> emissions, while also providing additional reductions in PM when coupled with a verified diesel emissions control system. This provides port drayage operators an alternative fuel selection for their existing fleet of container yard equipment.

### Benefits

The testing demonstrated that a 6 percent water emulsion effectively mitigated the NO<sub>x</sub> increase associated with the regular B20 biodiesel fuel. The inclusion of a DOC after-treatment unit showed a beneficial effect on the total PM emission reduction by 40 percent in comparison to a 29 percent reduction with the fuel as a stand-alone emissions control strategy. Additionally, there were no perceptible operational differences in the dedicated top handlers during the demonstration.

### Project Costs

Funding for the emulsified biodiesel demonstration was provided by POLB and POLA, each contributing \$44,000, for a total of \$88,000 in TAP funding for this project. APT committed matching funds in the amount of \$88,000 towards the demonstration project as well as committed to pursue CARB Level 2 verification for both their emulsified diesel fuel and their fuel in combination with currently verified diesel exhaust after-treatment systems.

### Commercialization and Applications

APT plans to leverage the findings of this TAP demonstration by pursuing their plans for CARB verification of the emulsified biodiesel fuel. This would enable future sales and marketing of the APT biodiesel blend fuel to existing cargo handling equipment fleet operators in the state of California.

---

<sup>12</sup><http://www.cleanairactionplan.org/civica/filebank/blobdload.asp?BlobID=2533>

## Balqon E-30 Electric Terminal Tractor Development & Demonstration Project

**Technology Manufacturer**  
Balqon Corporation

**Co-Participants**  
Port of Los Angeles  
South Coast Air Quality Management District  
(SCAQMD)



### Background

The Balqon E-30 Electric Terminal Tractor was built as a demonstration vehicle, co-funded by the Port of Los Angeles and SCAQMD, and designed specifically for drayage operations. Developed by the Balqon Corporation as a Port of Los Angeles initiative, the prototype E-30 all- electric terminal tractor successfully completed cargo terminal tests during 2008.

### Project Objective

Today, fleets of hundreds of hostlers - which are mostly diesel vehicles and a small number of LNG test units - move thousands of containers each day between the Port's docks and terminal backland. The objective of the E-30 Electric Terminal Tractor demonstration project was to prove the performance capabilities and commercial feasibility and practicality of using zero-emission electric terminal tractors to perform this function.

### Technology Description

Designed specifically for short-haul or "drayage" operations, this heavy-duty terminal tractor can pull a 60,000 pound cargo container at a top speed of 45 mph, and has a range between 30 to 60 miles per battery charge. The battery charger can charge up to four electric trucks simultaneously in four hours and can also provide up to 60 percent of the charge in one hour to meet peak demands during daily operations. Key design and performance attributes of the Balqon E-30 electric terminal tractor are highlighted below:

<b>Vehicle Performance</b>	Maximum speed 45 mph; unloaded grade 10%, loaded 5%; Max GCWR 125,000 lbs; Range: unloaded 150 miles; fully loaded range 90 miles
<b>Vehicle Dimensions (inches)</b>	Overall – 210" X 96" X 120"; wheelbase 135"; fifth wheel height 46"; front wheel overhang 44", rear wheel overhang 31"
<b>Electric Motor</b>	300 hp rated 230 volt AC electric motor connected to flux vector variable frequency controller; 300% peak load rating
<b>Traction Controller</b>	Proprietary flux vector motor controller 240 KW liquid cooled; integrated CAN BUS and self-diagnostic system
<b>Traction Battery</b>	280 kW-hr lead acid battery pack, 336 Volt; battery management system monitors battery cell performance
<b>Battery Charger</b>	100 KW multi-vehicle fast charger; 4 charging ports standard; priority smart charge algorithm based on vehicle state of charge

**Benefits**

The Balqon E-30 is a zero emission electric vehicle using electric motors for motive power and batteries for energy storage; thus, “tailpipe emissions” for this low-speed electric terminal tractor are zero.

On a “kilowatt-hour of energy” cost basis, the Balqon electric truck costs approximately 20 cents per mile to operate. A typical class 8 diesel truck could cost anywhere from four to nine times as much, depending on the cost of diesel fuel and truck duty cycle.

**Status**

Following the completion of cargo terminal tests during 2008, the Los Angeles Harbor Commission approved the purchase of 20 electric trucks from the manufacturer as part of the “Green Terminal” program. These trucks will be deployed as a zero emissions alternative to fossil fuel-powered yard tractors. The Green Terminal program will also include the production of five on-road electric trucks. In total, the Port of Los Angeles is investing more than \$5.6 million to demonstrate the viability of electric drayage trucks.

**Project Costs**

The development and demonstration of the Balqon electric terminal tractor was co-funded by the Port of Los Angeles and SCAQMD at a total cost of \$527,000.

Project Partners	Contributions
Port of Los Angeles	\$263,500
South Coast AQMD	\$263,500



**Commercialization and Applications**

As a provision of future electric truck orders, POLA required Balqon to locate its manufacturing facility in the City of Los Angeles and pay the Port a royalty for every electric truck it sells or leases worldwide. Those funds will be used to advance other Port TAP initiatives. The new Balqon manufacturing plant will support the creation of approximately 50 new “green collar” jobs.

## Balqon Lithium-Ion Battery Demonstration

**Technology Manufacturer**  
Balqon Corporation

**Co-Participants**  
Port of Los Angeles



### Background

The Balqon Lithium-Ion Battery Demonstration project was a follow-on project to the Balqon Electric Terminal Tractor Demonstration TAP project completed in 2008. During this earlier project, the Port of Los Angeles TAP and the SCAQMD partnered to demonstrate a Class 8 electric truck for port drayage operations.

### Project Objective

The objective of this follow-on project is to evaluate and demonstrate a lithium-ion battery as a technological upgrade to the lead-acid battery pack used in the previous TAP demonstration. The advanced technology lithium-ion batteries were anticipated to provide more than double the vehicle range, without adding additional weight.

Lithium-ion batteries have several important advantages over competing battery technologies. Primarily, lithium is a highly reactive element which translates into a very high energy density in a much lighter package. The electrodes are composed of lightweight lithium and carbon, offering a much lighter weight as compared to other rechargeable batteries of a similar size. Lithium-ion batteries retain their charge longer than other battery chemistries, and exhibit no “memory effect” – some high energy density battery chemistries, such as nickel cadmium, can become degraded if recharged before the battery has been fully discharged. Lithium-ion batteries can be recharged without completely discharging with no battery degradation, and can withstand literally hundreds of charge/discharge cycles, increasing battery lifespan.

### Technology Demonstration

Under this demonstration, one electric drayage vehicle and electric yard tractor were converted from lead acid battery to lithium battery technology. The vehicles demonstrated include:

- Balqon Nautilus Model XE-30, a zero emission all-electric tractor designed to transport containers in terminal or on-road use applications. The 100,000 lb. capacity fifth wheel hydraulic lift can reduce operation time by 70% when compared to a conventional fixed fifth wheel design. The XE-30 is equipped with proprietary flux vector control technology equipped with five speed automatic transmission.
- Balqon Corporation Model Nautilus E20, a smaller, all-electric terminal tractor that can carry loads up to 60,000 lb. with a range of 40 miles on a single charge. The vehicle is equipped with a fast charge system to allow the vehicle to be fully charged in 30 to 45 minutes. The E20 model is designed to transport containers at shipping ports and large warehouses and is also equipped with the hydraulic fifth wheel.



The lithium battery cells were assembled into the battery packs at Balqon's Harbor City, California facility and fitted with a proprietary battery management system (BMS) specifically designed for lithium-ion battery chemistry and characteristics. This TAP project also supported development of new charging algorithms to allow fast charge the lithium-ion batteries using the existing Balqon fast charger.

Vehicle range tests were conducted using both dynamometer and field test protocols. Installation of lithium batteries was expected to increase range by a factor greater than two as compared to the lead acid battery-equipped vehicle. It was anticipated that unloaded range would increase to 180 miles on single charge. Range at a loaded weight of 60,000 pounds at 45 miles per hour during short haul drayage was expected to exceed 100 miles on a single charge.

### Results

In June 2009, Balqon completed assembly of a Nautilus E30 all-electric tractor retrofitted with lithium ion battery packs. A one-day demonstration of the Nautilus E30 confirmed a range of over 150 miles on a single charge with unloaded conditions at 80% depth of discharge. The new lithium-ion battery packs included Balqon's BMS, which allows batteries to be fast charged and self-equalize during idle operation. It is noteworthy that the lead-acid battery system provided 30 to 50 mile range under comparable test conditions.

### Status

As of late 2010, Balqon had not yet initiated the full-scale vehicle range testing (either on the dynamometer or in the field) and the Balqon TAP agreement expired. Due to project constraints, results were not quantified, however initial testing did indicate a range of greater than 150 miles. It was anticipated that that testing would be complete in 2011. Unfortunately, the testing was never completed, the last project payment was forfeited and POLA closed out the project in 2011.

### Benefits

Zero-emission drayage trucks provide significant environmental benefits. However, operational concerns regarding range and charging times limit the applicability of zero-emission technology for the dray industry. Completion of this advanced battery demonstration project supports the long-term goal of increasing the use of zero-emission electric truck technologies in the drayage truck sector.

### Project Costs

The total project cost was \$940,000. The Port of Los Angeles, under TAP, contributed \$400,000. Balqon Corporation provided the two vehicles as well as additional in-kind engineering and test resources; the Balqon contribution was valued in excess of \$540,000.

### Commercialization and Applications

In July 2009, Balqon announced the release of lithium-ion batteries as an alternative to lead acid traction batteries for its entire product line of Class 8 yard tractors and drayage vehicles.

## Capacity Plug-In Hybrid Electric Terminal Tractor

**Technology Manufacturer**  
Capacity of Texas, Inc.

**Co-Participants**  
Port of Long Beach, Port of Los Angeles  
Ports America, Total Terminals, Inc., and Yusen Terminals, Inc.

### Background

Terminal tractors are essential to the daily operations of a port terminal. However, they also consume large volumes of diesel fuel and generate significant levels of harmful diesel emissions within the ports they serve. The development and deployment of low-emission, high-efficiency terminal tractors are high priorities for the Ports under the Clean Air Action Plan.

In response to the need for environmentally friendly yard hostlers, Capacity of Texas, Inc. developed a Pluggable Hybrid Electric Terminal Tractor (PHETT™). The Port of Long Beach, in conjunction with Capacity, Ports America, and Total Terminals, Inc. (TTI) conducted a three-week trial of the PHETT™ from June 8 to June 25, 2009. Results from this trial are available for download from the TAP website<sup>13</sup>.

A follow-on trial test to evaluate improvements made to the PHETT™ following the initial trial was conducted from December 8 to December 29, 2009 at the Port of Los Angeles' Yusen Terminals, Inc. (YTI). The final report for this trial is available for download from the TAP website<sup>14</sup> as well.

### Project Objective

The purpose of the demonstrations was to evaluate the performance and emissions of the PHETT™. In order to characterize the PHETT™ duty cycle and measure its load factor, the vehicle was equipped with a multi-channelled data logging system. The PHETT™ fuel economy was evaluated using the data collected by the data logger and supplemented with information provided by Capacity and site demonstration partners. In addition, surveys were developed and distributed to operators and maintenance personnel to assess the overall capability of the PHETT™.



<sup>13</sup> <http://www.cleanairactionplan.org/civica/filebank/blobdload.asp?BlobID=2416>

<sup>14</sup> <http://www.cleanairactionplan.org/civica/filebank/blobdload.asp?BlobID=2517>



### Technology Description

The PHETT™ is a diesel-electric plug-in hybrid terminal tractor that uses a small diesel generator and a large lead-acid battery pack to provide power for vehicle operation. As a plug-in hybrid, the PHETT™ offers a modest all-electric range and higher overall efficiency, which can significantly reduce fuel consumption and emissions compared to a conventional diesel-fueled terminal tractor.

The PHETT™ operates as a series diesel-electric hybrid. In this configuration, all of the energy demands of the vehicle are supplied through the battery; regardless of whether the energy is stored in the battery by a grid-connected charger or the on-board diesel generator. Given a fully charged battery, the PHETT™ will operate entirely from battery power, providing a limited “all-electric range” with zero tailpipe emissions. Once the battery has been depleted to a predetermined state of charge, the diesel generator will start and attempt to sustain the current level of charge in the battery.

According to Capacity, this diesel-electric hybrid terminal tractor is a “charge sustaining series hybrid that utilizes a constant and efficient rate generator to supply power, reducing fuel consumption by as much as 60 percent and audible db by 30 percent.

Three electrical inverters are used to supply the vehicle subsystems with power. The inverters convert the DC voltage of the battery pack into AC voltage that is better suited to operate the numerous AC electrical motors in the PHETT™.

Additionally, several systems on the vehicle use a 12VDC auxiliary power supply including the safety light, radios, and cabin HVAC fan. Capacity estimates a fixed power draw of 500 watts, assumed to be constant while the vehicle is in use.

### Project Costs

TAP funding in the amount of \$29,500 was allocated to the Port of Long Beach PHETT™ demonstration and testing project. The Port of Los Angeles also conducted a follow-on study at Yusen Terminal, Inc (YTI) with non-TAP funding in the amount of \$32,000. Additional in-kind contributions were provided by Capacity, Ports America, TTI and YTI; however, the equivalent dollar values of these additional contributions were not quantified.

### Results

The load factor for the PHETT™ was determined by measuring the diesel generator output over the entire operating time of the PHETT™. During the demonstration at TTI, the PHETT's™ load factor was evaluated as 0.58, equivalent to an average engine load of 23.3 hp. The PHETT™ was estimated to achieve a 77% reduction in NO<sub>x</sub> emissions, and an 82% reduction in PM emissions compared, to the baseline diesel fleet (2002 levels). The emission rates of the PHETT™ were also found to be lower compared to a 2009 diesel yard tractor. Due to a lack of fueling logs, fuel economy improvements were difficult to verify; however, fuel improvements were estimated to be in the range of 28% to 60% over the baseline fleet.

During the demonstration of the “beta” unit at YTI, the PHETT’s™ load factor was determined to be 0.54, equivalent to an average engine load of 21.7 hp. The beta PHETT™ was estimated to achieve a 44% reduction in NO<sub>x</sub> emissions, and a 56% reduction in PM emissions compared to a 2009 diesel yard tractor at 43% load (CARB’s approved load factor for yard tractors). However, the emission rates of the PHETT™ were similar to those of a 2009 MY diesel yard tractor at actual load (18%). Fuel consumption measurements showed a 34% improvement over the baseline fleet. Information gathered from the operators and maintenance personnel at both Ports indicated no significant problems with the PHETT™ and comparable performance to diesel yard tractors.

Following this demonstration, Capacity has marketed the PHETT in various applications throughout the U.S. and internationally. However, because the PHETT utilizes a Tier 4-interim generator drive engine (genset), it does not meet the requirements for port yard tractors in California under CARB’s Cargo Handling Equipment regulation, which requires engines meeting Tier 4 final off-road or 2007 on-road emissions standards. Capacity has since focused their efforts on the development of a zero-emissions terminal tractor, the ZETT, powered by plug-in electric/hydrogen fuel cell technology.



## Characterization of Drayage Truck Duty-Cycles

### Technology Manufacturer

Not applicable

### Co-Participants

Port of Long Beach; Port of Los Angeles;  
TIAX, LLC

### Background

Currently, there are approximately 11,000 heavy-duty diesel drayage trucks in service at the Port of Long Beach and Port of Los Angeles. According to the Ports' 2010 emissions inventories, the drayage truck fleet is the second largest source of NO<sub>x</sub> emissions and the fourth largest source of DPM emissions at the Ports. Even with increasingly stringent emissions standards promulgated by regulatory agencies, the drayage truck source category must continue to be as clean as possible. The introduction of zero-emission, hybrid-electric or other advanced heavy-duty truck technologies into the drayage fleet has the potential to provide significant emission reductions for this source category.

### Project Objective

The Ports initiated the Drayage Truck Duty-Cycle Characterization project in order to provide drayage truck equipment manufacturers with a thorough understanding of typical duty cycles associated with drayage service. The goal of this project was to collect detailed duty cycle information for drayage truck operations in near-dock, local, and regional operation. This duty cycle information, and raw data collected for the study, is now available online<sup>15</sup> for equipment manufacturers to help accelerate and improve the development of advanced drayage truck technologies.

### Benefits

While this project did not result in direct emission reduction benefits, it is anticipated that a wide variety of clean heavy-duty drayage truck technology developers would benefit from this duty-cycle characterization project.

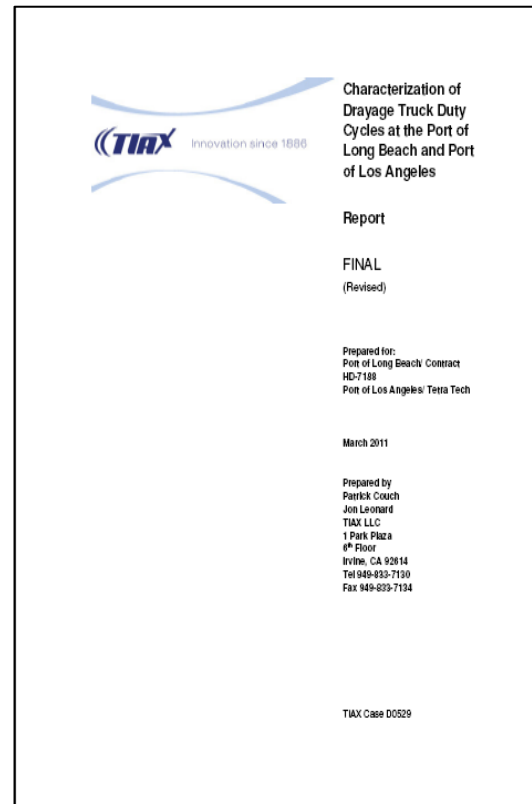

<sup>15</sup><http://www.cleanairactionplan.org/programs/tap/techdemos.asp>

### Results

For this project, vehicle operational data for multiple trucks were collected over a period of several weeks in the later part of 2010. Project trucks were equipped with data loggers and produced data in each of three operating regions: near-dock, local, and regional operation. The characterization of port drayage truck operation resulting from this project was used to develop a composite duty-cycle that will be used in upcoming drayage truck emissions evaluations. In addition, the duty-cycle will be distributed to engine and vehicle original equipment manufacturers (OEMs) with technology targeted to the drayage market.

Data from this study was used to develop a chassis dynamometer test schedule for drayage trucks serving the Ports in 2011. More information on the “Development of a Drayage Truck Chassis Dynamometer Test Cycle” project may be found in the body of this report.

### Project Costs

The Ports initiated this project to fulfill the need for drayage truck operational profiles that ports are uniquely positioned to support. The Ports contracted with Tetra Tech and their subcontractor TIAX, LLC, an internationally recognized expert in the field of duty-cycle characterization and development. The Ports funded the study to support future TAP efforts to support technologies that reduce emissions from heavy-duty trucks.

The combined TAP funding from both Ports was \$25,681.



## Development of a Drayage Truck Chassis Dynamometer Test Cycle

### Technology Manufacturer

Not applicable

### Co-Participants

Port of Long Beach, Port of Los Angeles,  
TIAX, LLC

### Background

In early 2011, the Port of Long Beach and Port of Los Angeles released a report authored by TIAX, LLC that characterized the duty cycle of on-road, Class 8 drayage trucks at the Ports. The report included statistics based on over 1,000 truck trips collected over a four-week period in late 2010. Based on these statistics, TIAX, LLC identified five modes of operation and an “average” trip associated with each mode. The statistics and trip data from this earlier work provided important information on the real-world operation of drayage trucks in the South Coast Air Basin.

### Project Objective

As a follow-up to the earlier “Heavy-Duty Drayage Truck Duty-Cycle Characterization” project, this study encompassed the development of a detailed driving schedule suitable for use when testing heavy-duty vehicles on a chassis dynamometer that is based on the modes of operation and trip data previously identified in the earlier study.

### Status/Results

The Port of Long Beach and Port of Los Angeles initiated this project to fulfill the need for drayage truck operational profiles that the Ports are uniquely positioned to support. The Ports contracted with Tetra Tech and their subcontractor TIAX, LLC, an internationally recognized expert in the field of duty-cycle characterization and development. The Ports funded the study to support future TAP and outside agency efforts to evaluate technologies that reduce emissions from heavy-duty trucks.

The chassis dynamometer test cycle was developed to provide the Port of Long Beach and Port of Los Angeles with a tool to compare the emissions performance from various drayage truck technologies. While this cycle was developed using actual in-use vehicle data and methods similar to those used to develop the widely used heavy heavy-duty diesel duty truck (HHDDT) test cycle used by test labs nationwide, this new drayage truck cycle has not yet benefitted from validation on a chassis dynamometer.

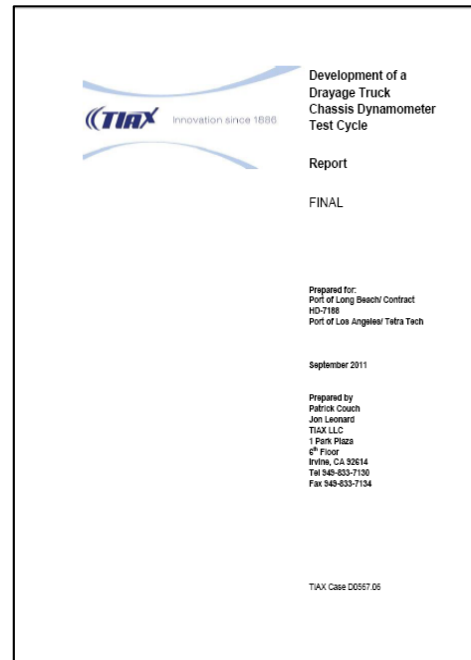

## San Pedro Bay Ports Technology Advancement Program 2012 Annual Report

The final report is available in the public domain for all interested parties to utilize. The final report can be accessed at the Ports' Clean Air Action Plan website at <http://www.cleanairactionplan.org/civica/filebank/blobdload.asp?BlobID=2526>.

The SCAQMD is emissions testing several heavy-duty vehicles, including diesel and liquefied natural gas drayage trucks, as part of their HDV In-Use Emissions Testing Program. The Ports provided the test cycle developed in this project for use in SCAQMD's multi-vehicle testing program. The drayage truck cycle will be used to assess drayage truck emissions and will also be used to compare the results of the drayage truck test cycle to other existing cycles.

### Benefits

The successful completion of this study resulted in a test cycle that reflects typical port drayage truck operation. Use of this cycle in emission testing programs and engine/vehicle system design projects will help ensure that emission reduction efforts of agencies and technology developers will result in information or products that are relevant to port operation or can meet rigorous port duty cycles.

### Project Costs

The Ports shared the cost of this study. The Port of Long Beach contributed \$12,000 and the Port of Los Angeles contributed \$11,466.



## Foss Maritime Green Assist™ Hybrid Tugboat

### Technology Manufacturer

Foss Maritime  
Aspin Kemp & Associates  
XeroPoint

### Co-Participants

Port of Long Beach, Port of Los Angeles, South Coast Air Quality Management District, California Air Resources Board



### Background

Foss Maritime achieved several significant milestones in the development of the World's first diesel electric hybrid tugboat. Christened the *Carolyn Dorothy*, the FOSS Green Assist™ hybrid tug was unveiled on January 23, 2009 and began working in the harbor immediately, even though some systems were still being commissioned. All system commissioning was complete on March 1, 2009, at which point the *Carolyn Dorothy* became a full working member of the Foss Maritime tug fleet. Since this time, the hybrid tug demonstrated performance comparable to a conventional Dolphin Class tugboat.

### Technology Demonstration

The Green Assist™ hybrid tug was built by Seattle-based Foss Maritime in partnership with Aspin Kemp & Associates and their affiliate XeroPoint, which developed the unique hybrid power management system. At the heart of the Foss Green Assist™ project is the Dolphin class tug currently operated by Foss at the Ports of Long Beach and Los Angeles. The conventional diesel-fueled tugs are powered by Caterpillar main engines producing a total of 5,080 bhp and a bollard pull of 60 tons. Externally, the *Carolyn Dorothy* is quite similar in appearance to its conventionally powered forebears. The only noticeable evidence of its unique power plant is a pair of smaller exhaust stacks.

The tug's diesel-battery-electric propulsion system comprises two fully azimuthing propulsion units powered by batteries, diesel generators and/or two diesel main engines. A modified engine room accommodates two battery packs, producing the equivalent of 670 horsepower, and two 335 horsepower diesel powered generators. The main engines are substantially smaller and less powerful than those in the existing Dolphin class tugs.

An essential feature is the power management system required to produce seamless transition from one power source to another, depending on the tug's duties and the power demand. In its various modes of operation, the new tug employs battery power idling and no-wake low speed maneuvering and a combination of battery and generators for transiting. When full power is required, the diesel main engines start automatically and are coupled by clutches to the drive system in addition to the electric motors. Surplus power generated at any stage is used to recharge the battery packs.

Although the main engines in the new tug are smaller than those of existing vessels, the same total horsepower and the same 60 tons bollard pull is available. The Green Assist™ Tug has four distinct modes of operation:

**STOP** - When the tug is docked at the pier. Main engines are off-line; power is provided by batteries for hotel loads (lighting, HVAC, etc.) and can be recharged by shore power;

**IDLE** - When the vessel is not secured to a pier but is stopped at sea. Main engines are off-line. Batteries provide power for hotel loads and station keeping. A generator automatically starts up and comes on line to recharge batteries;

**TRANSIT** - Continuous slow and fast transit 6-8 knots. One generator for the slower “harbor – speed” transit of approximately 6 knots. The second generator automatically starts when the throttle setting calls for a faster speed transit of about 8 knots. Batteries provide “ride-through” power until the second generator is online. The generators also are providing hotel loads and are recharging the batteries while simultaneously providing the propulsive power.

**ASSIST** - Full power ship-assist requirements. Both main engines, generator sets and batteries provide full power.

Based on the operating profile of the conventional Dolphin tugs currently operating in the Ports, it is estimated that the hybrid will spend at least 75 percent of its operating hours in the operating modes without main engines. Only batteries and generators are used during idle or low speed/low load operation, but the vessel is able to access full power on demand.

## Results

Foss completed development of the project test plan in September 2009, and formed a Technical Working Group (TWG) with Foss, POLB, POLA, CARB, EPA, SCAQMD, and the Pacific Merchant Shipping Association (PMSA) in the fall of 2009. In late 2009, the UC Riverside College of Engineering – Center for Environmental Research and Technology (CE-CERT) began test equipment acquisition and software code upgrades to prepare for test plan implementation. Full system and emissions testing was conducted in early 2010. This project’s final report is available for download from the TAP website<sup>16</sup>.

## Benefits

The hybrid tugboat achieved emission reductions that exceed original targets (to reduce both NO<sub>x</sub> and PM by approximately 44%) when compared with the Dolphin tugs currently operating in the San Pedro Bay. The *Carolyn Dorothy* reduced PM, NO<sub>x</sub> and CO<sub>2</sub> emissions by 73%, 51% and 27%, respectively<sup>17</sup>. Based on this evaluation, fuel consumption is reduced by approximately 20 to 30 percent.

The measured emission levels of the *Carolyn Dorothy* are cleaner than the U.S. EPA’s Tier 2 emissions standard for marine engines. Along with less pollution, the Green Assist™ tug offers improved fuel economy and requires significantly less maintenance. It is also quieter than its Dolphin sister tugs when operating on batteries that can be recharged using environmentally friendly shore power.

---

<sup>16</sup><http://www.cleanairactionplan.org/civica/filebank/blobdload.asp?BlobID=2501>

<sup>17</sup><http://www.cleanairactionplan.org/civica/filebank/blobdload.asp?BlobID=2502>



### Project Costs

The overall cost for the design, development and commissioning of the *Carolyn Dorothy* was over \$8 million. The Port of Long Beach provided \$500,000 in TAP funding, and the Port of Los Angeles provided \$889,920 in non-TAP funding to support this project. Additional in-kind support was provided by CARB and SCAQMD. Remaining costs were covered by Foss Maritime.

### Commercialization and Applications

The Port of Long Beach and the Port of Los Angeles teamed with Foss to implement the “Tugboat Hybridization Project”. This \$2.3 million project is funded in part by a \$1 million grant from CARB’s AB 118 Air Quality Investment Program. The tugboat *Campbell Foss* was retrofitted with hybrid technology, followed by an in-service evaluation for emissions reductions and fuel savings. The tugboat has been incorporated into Foss’ operations.



## Hybrid Yard Tractor Development & Demonstration

### Technology Manufacturer

US Hybrid

### Co-Participants

Port of Los Angeles, Port of Long Beach, CALSTART, U.S. Environmental Protection Agency, Kalmar Industries, Long Beach Container Terminal (LBCT)

### Background

The TAP investigated the feasibility and commercial viability of using advanced technology drive systems in cargo handling equipment. The TAP, in partnership with the U.S. EPA's West Coast Collaborative, worked together to develop and test hybrid technology yard tractors for use at container terminals.

Yard hostlers (also known as yard tractors, terminal tractors, or utility tractor rigs) are common at port terminals, rail yards, and distribution centers. Their function is to move containers around the facility. At a port, containers are loaded off a ship onto a bobtail rig that is pulled by the yard hostler to an intermodal point or to a storage facility. Yard hostlers often sit idling as they wait in queues to pick up or drop off their loads.

### Project Objective

The Ports of Long Beach and Los Angeles partnered with CALSTART, a non-profit company that focuses on advancing cleaner technologies, to manage the demonstration of three (3) diesel-hybrid yard hostlers at the Long Beach Container Terminal (LBCT). The U.S. EPA also provided grant funds for the design and development of the hybrid drive system. Vehicle emissions and performance were evaluated relative to diesel yard hostlers, and a business case/lifecycle cost benefit assessment was performed to determine the financial viability for large-scale use of hybrid yard hostlers in marine terminals.

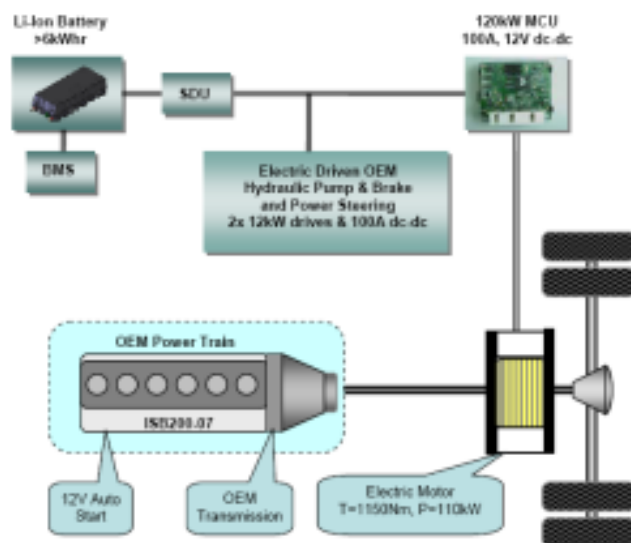

### Technology Description

US Hybrid was selected as the hybrid drive system supplier through a competitive bid process. US Hybrid designed and developed a diesel-electric parallel hybrid, post-transmission configuration system that was integrated into a Kalmar Industries Ottawa 4x2 terminal tractor.

### Benefits

The three hybrid yard hostlers underwent six months of operation and in-use testing at LBCT and were able to perform all the tasks required of yard hostlers in real-world port operations, and were well accepted by drivers and maintenance staff. Fuel economy and emissions benefits were evaluated, but a difference discovered in the mechanical specifications of the vehicles limited comparability. Based on all the evaluations and analyses conducted, the hybrid system is estimated to provide a 12% to 18% improvement in fuel economy. Further development of the hybrid system is underway in an effort to improve fuel economy and emissions reductions. The lifecycle cost assessment for large-scale use of hybrid yard hostlers showed that incentives of approximately \$18,000 per vehicle would be needed to ensure payback of the hybrid system. The final report for this project is available for download from the TAP website<sup>18</sup>.

### Project Costs

The project was valued at \$1.2 million. The Ports contributed \$300,000 each and the U.S. EPA contributed \$300,000 through a West Coast Collaborative grant. LBCT and other project suppliers provided in-kind labor contributions estimated at \$300,000. CALSTART provided technical project management assistance.



<sup>18</sup><http://www.cleanairactionplan.org/civica/filebank/blobdload.asp?BlobID=2516>

## Hybrid Yard Tractor Development & Demonstration – Beta Test

**Technology Manufacturer**  
US Hybrid

**Co-Participants**  
Port of Long Beach, Port of Los Angeles, Long Beach Container Terminal

### Background

Terminal operators at the Ports currently operate more than 1,500 yard hostlers in three service types: ship, rail, and yard service. Ship service consists of the transport of containers between a ship and the container stacks inside the terminal. Rail service is similar to ship service except that containers are transferred to and from rail cars. Yard service (also called dock work) involves moving containers between stacks or to/from loading areas for drayage trucks.

For the majority of the demonstration period, LBCT had use of only one US Hybrid yard hostler. Ship service provided the greatest amount of vehicle operation and fuel consumption data possible, relative to the other two service types, therefore LBCT elected to use the US Hybrid yard hostler in ship service. Late in the demonstration, a second US Hybrid unit was made available to LBCT and this unit was placed into rail service.

### Project Objective

As a follow-on Hybrid Yard Tractor Development & Demonstration Project<sup>19</sup> conducted in 2010, the Port of Long Beach, Port of Los Angeles, US Hybrid and Long Beach Container Terminal (LBCT) assessed the potential in-use fuel economy performance of newly modified hybrid yard hostlers from February to June 2011 under a new project, Hybrid Yard Tractor Development & Demonstration – Beta Test.

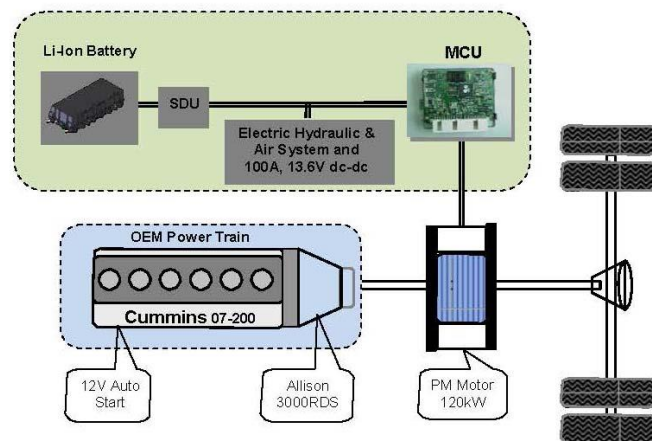

<sup>19</sup> Final Report entitled “Hybrid Yard Hostler Demonstration and Commercialization Project” available for download at: <http://www.cleanairactionplan.org/civica/filebank/blobload.asp?BlobID=2516>

### Technology Demonstration

The hybrid yard hostlers demonstrated consist of standard Kalmar Ottawa yard hostlers fitted with a parallel hybrid-electric power trains. Following the initial demonstration of the hybrid yard hostlers in 2010, US Hybrid made modifications to the hybrid system to improve fuel economy from the previous demonstration. In particular, US Hybrid altered the battery management algorithm, hybrid control algorithm, idle management strategy, and increased the capacity of the traction battery. These modifications resulted in a Generation 1.1 configuration. Near the end of the current demonstration, US Hybrid provided a second unit to LBCT that incorporated several additional modifications, including changes to the transmission control algorithm, electric motor, and motor control unit. This configuration is referred to as Generation 2.0.

### Status and Results

The results of the analysis support the following conclusions:

1. Based on the iDrive data acquisition system and paper fuel logs completed by LBCT, the Generation 1.1 yard hostler placed into service at LBCT did not demonstrate significantly different fuel economy compared to either the baseline yard hostler or the Generation 1.0 hybrid yard hostler tested during the previous demonstration.
2. Because the Generation 2.0 yard hostler was placed into service close to the end of the demonstration period, there was insufficient fuel consumption data collected to make any conclusions regarding its fuel economy.
3. Generation 2.0 yard hostlers have been redesigned to address the fuel economy performance issues encountered in the previous demonstration. The consistency of fuel consumption data and the high level of use of tractors in service make this the preferred service to demonstrate the Generation 2.0 or future generation hybrid yard hostlers.

Following the completion of the project, the hybrid systems were removed and the vehicles returned to their original state by Kalmar. Further demonstration of the hybrid drive technology in yard hostlers continues in a separate parallel project conducted by the New York Power Authority and the Port Authority of New York/New Jersey. Three of the newer generation hybrid yard hostlers have been operating in day-to-day terminal operations at New York Container Terminal since 2010. Similar to the project conducted at LBCT, the hybrid vehicles' in-use performance and fuel economy is being assessed. In addition, chassis dynamometer emissions testing will be conducted. The TAP will continue to monitor the progress of the project.



### Project Costs

The total cost of the supplemental demonstration was \$26,000 which was split evenly between the two Ports (or \$13,000/port).

## Liquefied Natural Gas (LNG) Yard Tractor Project

### Technology Manufacturer

Kalmar Industries  
Cummins Engine Company

### Co-Participants

Port of Long Beach, U.S. EPA Region 9, Long Beach Container Terminal, CALSTART

### Background

Yard tractors, also referred to as yard hostlers, terminal tractors, and yard goats, are heavy-duty off-road truck tractors designed for moving cargo containers within port container terminals and other off-road areas. These vehicles are the most common type of cargo handling equipment (CHE) used at container terminals at the Ports. According to emission inventories compiled by the Ports of Long Beach and Los Angeles, yard tractors emit approximately 64% of the particulate matter (PM) and 59% of the nitrogen oxides (NO<sub>x</sub>) emissions for all cargo handling equipment, as shown in Figures 2.3-1 and 2.3-2, below. Further, yard tractors are the single largest landside source of PM and NO<sub>x</sub> emissions at the Ports.

### Project Objective

To investigate the technical and commercial feasibility of reducing emissions from yard tractors, the Port of Long Beach, in partnership with the U.S. EPA, funded the demonstration of yard tractors equipped with low-emission liquefied natural gas (LNG) engines.

### Technology Demonstration

The project was divided into three phases. The first phase focused on development of LNG yard tractor specifications, procurement, and installation of temporary LNG refueling.

Phase 2 included operation of the LNG yard tractors at a marine terminal for a period of eight months. Demonstration commenced in June 2006 and was completed in January 2007. During this time, data were collected on the performance of the LNG yard tractors compared to a group of baseline diesel vehicles. Emissions testing was also conducted at the conclusion of the second phase.

The third phase of the project was the development of a business case assessment to determine the cost-effectiveness and return on investment of using LNG equipment as opposed to diesel.

The project team consisted of the Port of Long Beach, U.S. EPA Region 9, Sound Energy Solutions, CALSTART, and Long Beach Container Terminal (LBCT). LBCT volunteered to test the LNG yard tractors in their container terminal operations during the eight month evaluation period.



A total of three LNG yard tractors were deployed for performance testing and evaluation. Specifications for the LNG yard tractors were based on the Ottawa Commando 50 4x2 off-road terminal tractor performance specifications.

The LNG engine specified for the demonstration was the model year 2005 Cummins C Gas Plus 8.3 liter natural gas engine, rated at 250 hp and certified to the CARB on-road Optional NO<sub>x</sub> standard.

Eight diesel yard tractors were selected from LBCT's fleet to serve as the baseline yard tractor group for comparative purposes. The baseline vehicles were equipped with various off-road diesel engines, ranging from model year 2001 to 2003 Cummins 8.3 liter 6CT engines rated at 205-215 hp and certified at Tier 1 or Tier2, to model year 2005 Cummins 5.9 liter ISB engines certified to the on-road emissions standard. All baseline diesel engines were equipped with diesel oxidation catalysts and closed crankcase ventilation (CCV) to reduce particulate matter emissions. Data was collected on the baseline yard tractor group in parallel with the LNG tractors under similar operating conditions.

### Results

Data collection was performed for quantitative parameters, such as fuel consumption and exhaust emissions, as well as qualitative attributes, such as operator perceptions of vehicle drivability. With respect to fuel economy, the LNG yard tractors used approximately 30% more fuel, on a diesel equivalent gallon basis, as compared to the average for baseline diesel vehicles. This result is consistent with expectations for the relative efficiency of a spark-ignited natural gas engine compared to a compression-ignited diesel engine.

Operator acceptance was assessed via surveys given to all LNG yard tractor drivers. Drivers were asked to rate the LNG yard tractor as "better", "same", or "worse" in key performance areas compared to a typical diesel tractor. The areas covered by the survey included maneuverability, pulling power, acceleration, shifting, steering, in-cab visibility, ride comfort, etc.

Based on the driver surveys, 97% of the drivers found the LNG yard tractors to have the same or better performance compared to the diesel tractors; 67% of the drivers rated the LNG tractors as having superior performance in general.

### Benefits

During emissions testing, the lowest NO<sub>x</sub> and PM emissions were produced by the 2005 on-road diesel engine-equipped tractor and the 2005 LNG tractor, respectively. NO<sub>x</sub> emissions from the LNG yard tractor were approximately 21% higher than NO<sub>x</sub> emissions from the on-road diesel engine equipped with a diesel oxidation catalyst and closed crankcase ventilation system.

### Project Costs

The total project cost was \$425,000. Funding included \$350,000 from the Port of Long Beach TAP Program and a \$75,000 contribution from U.S. EPA Region 9.

### Commercialization and Applications

Original Equipment Manufacturer (OEM) yard tractor chassis manufacturers now offer LNG yard tractors equipped with the Cummins Westport ISL G natural gas engine. This 8.9 liter heavy-duty on-road engine is certified at the 2010 0.2 g/bhp-hr NO<sub>x</sub> emission standard.

## Long Beach Container Terminal EcoCrane™

### Technology Manufacturer

R.J. Corman EcoPower Hybrid Systems, Inc., formerly Railpower Technologies, Inc.

### Co-Participants

Port of Long Beach, Port of Los Angeles, Long Beach Container Terminal

### Background

This project involved the demonstration of a rubber tired gantry crane (RTG) equipped with an advanced energy capture and battery storage system. The system, called EcoCrane™, was developed by R.J. Corman EcoPower Hybrid Systems, Inc., formerly Railpower Technologies, Inc. The project was sponsored by the Port of Long Beach (POLB) and Port of Los Angeles (POLA) under the joint Technology Advancement Program (TAP).

### Project Objective

A conventional diesel-electric RTG uses a diesel-fueled engine to generate electricity that powers electric motors used in container lifting as well as the motive power to move the RTG along the container stack. An RTG diesel genset used in port operations has a diesel engine rated, on average, at greater than 600 horsepower.

In the EcoCrane™ configuration, the diesel genset is equipped with a much smaller diesel engine – less than half of the rated horsepower of a conventional RTG. The reduced engine size and ability to turn the engine off during idling results in significantly lower fuel consumption and exhaust emissions. In addition, the smaller engine used in the EcoCrane™ genset is rated by the EPA at Tier 3, representing the current state-of-the-art diesel engines for off-road applications. This enables the EcoCrane™ to achieve substantial emission reductions as compared to a conventional RTG.





**Technology Demonstration**

During operation of a conventional diesel genset RTG, electric motors are used to lift the container and reposition the RTG along the container stack. Once in the proper position, the RTG lowers the container at a controlled rate. In a conventional RTG, the energy available when a container is lowered is wasted. In contrast, a hybrid RTG configuration captures the energy associated with lowering a container and stores in an energy storage system.

The EcoCrane™ uses a regenerative braking energy capture and storage system, similar to a hybrid-electric automobile. When a container is lowered using the EcoCrane, the motor used to lift the container is “reversed”; the motor becomes a generator, and the electricity produced as the container is lowered is directed to a bank of batteries - the electric energy storage system. The energy stored in the batteries can then be used to augment the EcoCrane’s™ electric motor during the crane’s subsequent lift.

Because batteries provide a portion of the energy used by the EcoCrane™ during container lifting, the amount of energy required from the diesel genset is substantially reduced. In the EcoCrane™ hybrid electric configuration, the reduction in power required from the diesel genset is greater than 50 percent. This means that the existing diesel genset can operate at a much lower load factor. The EcoCrane™ hybrid RTG is equipped with a 134 kW (180 brake horsepower (bhp)) Tier 3 John Deere diesel engine. This engine replaced a Cummins KTA-19 diesel engine rated at approximately 507 bhp at an engine speed of 1,800 RPM. Therefore, the EcoCrane™ diesel engine is approximately 65 percent smaller than the conventional RTG diesel engine in terms of rated power. A comparison of the EcoCrane™ diesel engine as compared to the original RTG diesel engine is shown below.

**EcoCrane™ Diesel Genset Engine as Compared to RTG Diesel Genset Engine**

	Conventional RTG Cummins KTA-19	EcoCrane™ RTG Tier 3 John Deere
Rated Horsepower (bhp)	507	180
Fuel Consumption (1,800 RPM)	27.3 gallons per hour	9.1 gallons per hour
NOx + Hydrocarbon Emissions Standard	4.8 g/bhp-hr	3.0 g/bhp-hr

**Status**

The experience gained from the LBCT project resulted in EcoPower Hybrid Systems modifying the original EcoCrane design and developing a second-generation EcoCrane™ hybrid RTG system. The new design is equipped with alternating current (AC) motors and eliminates the high power inverter. Control, power electronics, and hardware have also been improved. In addition, the new EcoCrane™ configuration is equipped with a dual battery pack with a total capacity of 440 amp-hours (Ah), compared to the LBCT EcoCrane™ battery capacity of 180Ah. This new battery configuration was designed to adapt to the voltage and energy requirements of existing RTG drive systems.

### Results and Benefits

The LBCT EcoCrane™ project demonstrated the application of hybrid-electric technology to cargo handling equipment in a marine terminal environment. Significant reductions in criteria air pollutant emissions, as well as reductions in fuel consumption and greenhouse gases, are being achieved by the EcoCrane™ as compared to a conventional diesel-electric RTG. Specifically, NOx plus hydrocarbon emissions of the Tier 3 John Deere engine are approximately 38 percent lower than RTG original equipment engine. Fuel consumption of the smaller John Deere engine is also significantly lower than a conventionally-equipped RTG.

### Project Costs

The cost of the demonstration project was \$169,870, with LBCT providing a fifty-percent cost share. The balance of funds, \$84,935, was provided by the TAP.

### Commercialization and Applications

Ports America is demonstrating the next generation of EcoCrane™ at the Port of Los Angeles' West Basin Container Terminal. The new design has targeted reductions in diesel particulate matter of 85 percent and reductions in greenhouse gases on the order of 70 percent.

Following successful completion of the demonstration phase, it is expected that EcoPower Hybrid Systems, Inc. will seek EPA and CARB verification for the EcoCrane™ system.



# RYPOS Advanced Diesel Particulate Filter for Cargo Handling Equipment

**Technology Manufacturer**  
RYPOS, Inc.

**Co-Participants**  
Port of Long Beach, Port of Los Angeles

## Background

Although rubber tired gantry (RTG) cranes account for roughly 5 – 6 % of cargo handling equipment at the Ports of Long Beach and Los Angeles, RTG cranes have been a significant contributor to port emissions.

## Project Objective

To investigate the technical and commercial feasibility of reducing emissions from RTG cranes and other cargo handling equipment equipped with an active diesel particulate filter.

## Technology Demonstration

RYPOS ActiveDPF/C™ system consists of the filter housing, flow control, electrical control circuit, and filter cartridges. The electrical control circuitry automatically monitors and controls the regeneration of the filter cartridges.

The diesel particulate filter cartridge is composed of sintered metal fibers that are shaped into filter elements and then incorporated into filter cartridges. These sintered metal fiber cartridges are capable of capturing the very fine carbon particles present in the exhaust stream, with high efficiency and high holding capacity. The diesel oxidation catalyst filter cartridge reduces CO, NO<sub>2</sub>, and hydrocarbon emissions, and can act as a sound absorption device, replacing the muffler while occupying the same space.

The operation of the RYPOS ActiveDPF/C™ is controlled by a microprocessor. The controller monitors the filters and, as required, an electric current is passed through a filter element, which then acts as a heating element. A dedicated power source provides the required electrical current to heat each filter element individually to the temperature required to burn soot, reducing the maximum amount of electrical energy required. This regeneration strategy is designed to keep the back pressure below a pre-set level. The average power consumption required for regeneration is less than one percent of the rated power of the engine.

The proposed project demonstration consisted of installing the system on a RTG crane, a top handler and a side handler.

### Results

In early 2012, RYPOS prepared and submitted to the California Air Resources Board an in-use operation test plan for review. During that time, tests conducted on the filter prompted a reevaluation of voltage needed for optimum regeneration as well as filter design and sizing. With much of their time focused on obtaining Level 3 verification for the RTG crane application, RYPOS determined that it was unable to move forward on developing the Active DPF/C™ system for top and side handler application. As a result, RYPOS has completed their obligations under the TAP and the project is considered complete.

### Benefits

In August 2011, the RYPOS ActiveDPF/C™ was verified by CARB to reduce particulate matter in the RTG crane application at CARB Level 2-plus verification (50%, but actual test results showed 83% effectiveness). RYPOS will continue to modify the system to achieve Level 3 verification for CHE.

### Project Costs

The total project cost was \$322,140. Funding included \$64,668 from the Port of Long Beach TAP Program and a \$64,688 contribution from the Port of Los Angeles TAP Program.

### Commercialization and Applications

RYPOS is currently pursuing Level 3 verification (at least 85% PM reduction) of the Active DPF/C™ system for RTG cranes by adjusting the software that dictates how often regeneration occurs on an RTG crane at TraPac at the Port of Los Angeles. The demonstration is being completed outside the scope of this TAP project; Ports staff will follow any progress made to provide status updates of the technology to interested terminal operators.

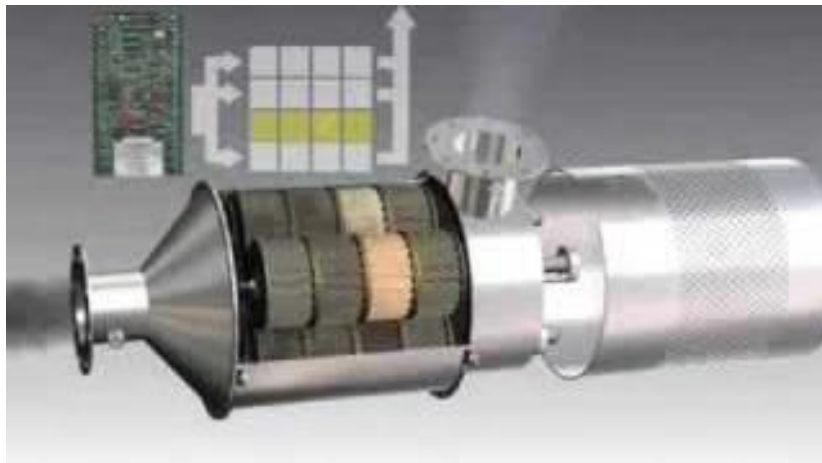

## SoCalGas CNG Drayage Truck Demonstration

### Technology Manufacturer

Cummins Westport

Autocar LLC

### Co-Participants

Port of Long Beach, Port of Los Angeles, SoCalGas Company, California Cartage Company, South Coast Air Quality Management District



### Background

The Ports are committed to reducing air pollution from drayage operations as exemplified by their respective Clean Truck Programs and research into zero-emission container movement. The TAP is also supporting the Ports' transition to low emission drayage operations by demonstrating technologies that have high potential to be both commercially viable and significantly reduce pollution from container drayage.

### Project Objective

Under the TAP, the Ports embarked upon a collaborative effort with Southern California Gas Company (SoCalGas) and their partners, California Cartage Company and Autocar LLC, to develop and demonstrate the nation's first drayage trucks powered by compressed natural gas (CNG). Four trucks were delivered June 2008 and used to move containers between the Ports and nearby freight consolidation yards.

### Technology Demonstration

The trucks were manufactured by Autocar LLC and are powered by the Cummins Westport ISL G engine. The Cummins Westport ISL G is currently the cleanest heavy-duty internal combustion engine commercially available, with certified NO<sub>x</sub> levels one-half that of U.S. EPA's stringent 2010 on-road heavy-duty emissions standard.

To demonstrate the viability of the ISL G CNG engine in port drayage operations, California Cartage Company (CCC), the largest trucking company operating at the Ports, operated the four CNG-powered trucks in regular revenue drayage operations for a one-year demonstration period. This period covered calendar year 2009. During this period, the trucks underwent continuous monitoring to assess performance capabilities, operability, driver impressions, and vehicle reliability.

### Status

The CNG trucks operated throughout 2009. Initially, the trucks were used exclusively in local drayage service around the Ports in an effort to familiarize the drivers with the new vehicles and to build confidence in the local, public CNG infrastructure. In early May 2009, CCC's management decided they had the comfort level with the TAP-funded CNG truck to begin running it on longer inland routes. Beginning on May 4, 2009, the TAP-funded CNG truck began running one inland route from CCC to Ontario each morning. The truck ran local routes each afternoon. The CNG truck continued running this single daily inland route for most of May 2009 through September 2009. After September, the CNG truck was returned to in-service operation until reclaimed by SCG for further research purposes in 2010.

### Results

The SoCalGas demonstration proved the feasibility and capability of using CNG fuel in commercially available heavy-duty engines for port drayage operations. This provides port drayage operators an additional low emission technology choice when replacing or upgrading their fleet vehicles. This project's final report is available for download on the TAP website<sup>20</sup>.

### Benefits

The certified NO<sub>x</sub> emission levels of the Cummins Westport ISL G engine are about 90 percent below a model year 2007 diesel drayage truck. The use of "low carbon content" natural gas will also help California achieve its goals under its Low-Carbon Fuel Standard and reduce greenhouse gas emissions by approximately 20 percent as compared to diesel fuel.

### Project Costs

The combined TAP funding from both Ports was \$223,155, which was applied to the capital purchase cost of one demonstration vehicle. The remaining three demonstration trucks were purchased by SoCalGas. The SCAQMD co-funded the construction of a temporary CNG refueling station to support the demonstration trucks' daily refueling needs. The SCAQMD also contributed \$421,250 towards the purchase of capital equipment for the temporary refueling station.



### Commercialization and Applications

The Cummins Westport ISL G engine is commercially available today, and an increasing number of heavy-duty truck chassis manufacturers are offering vehicles equipped with the ISL G in a compressed natural gas configuration. The 8.9L engine is marketed as meeting 2010 US EPA and CARB emission standards. In addition, the relatively low cost of CNG, as compared to diesel fuel, makes this engine an attractive option for port drayage operators.

---

<sup>20</sup><http://www.cleanairactionplan.org/civica/filebank/blobdload.asp?BlobID=2471>

## Vision Motor Corp. Hydrogen Fuel Cell Plug-In Hybrid Electric Trucks

### Technology Manufacturer

Vision Motor Corp.

### Co-Participants

Port of Long Beach, Port of Los Angeles

### Background

Zero-emission vehicles (ZEVs) provide significant environmental benefits. Tailpipe emissions are completely eliminated, and even on a lifecycle basis (i.e., including the fuel cycle emissions of hydrogen versus petroleum diesel fuel production and distribution), the ZEVs are cleaner than conventional alternatives. This project was designed to support the joint Port effort to increase the use of zero-emission technology in port equipment. This effort is detailed in the “Roadmap for Moving Forward with Zero Emission Technologies at the Ports of Long Beach and Los Angeles.”

### Project Objective

To demonstrate a zero emission hydrogen fuel cell/hybrid-electric drive system in short-haul drayage and terminal container movement operations.

### Proposed Technology Demonstration

The project includes the design, development and demonstration of two vehicle types: 1) the Tyrano™ class 8 on-road truck equipped with Vision’s proprietary hydrogen (H<sub>2</sub>) fuel cell/hybrid electric drive system; and 2) the Zero-TT off-road terminal tractor equipped with a similar zero-emission hybrid drive system. During the demonstration, each vehicle will undergo performance testing to validate maximum speed and maximum daily operating range under various payloads and conditions.

The Class 8 truck is powered by a battery electric drive system that incorporates a hydrogen fuel cell range extender. The design specifications include an estimated 8-hour shift with a range of 200 miles, a governed maximum highway speed of 65 miles per hour, and ability to haul an 80,000 pound payload.

The Zero-TT is equipped with a similar battery electric drive system with a hydrogen fuel range extender. The design specifications include an estimated 8-hour shift with a range of 100 miles and the ability to haul a 130,000 pound maximum container.

### Results

Both projects fell significantly behind schedule, and Vision was unable to begin the demonstrations within the contractual time period. The contract expired at the end of 2012; at that time, there were no results to report from the TAP testing period. Vision continues to develop the vehicles and conduct mini-demonstrations with its private partners.

### Benefits

Vision was unable to provide proof of environmental benefits conforming to the TAP test plans during the project demonstration period. However, Vision continues to test these vehicles and refine the technology.

### Project Costs

The original project budget was \$999,211 with \$425,000 in TAP funding and \$574,211 from Vision in matching funds. TAP funding in the amount of \$191,250 was spent on the project prior to contract expiration.

### Commercialization and Applications

At this time, these zero-emission vehicles are considered emerging technologies in the demonstration phase with no immediate plans for CARB verification or commercialization. Any future demonstrations of these technologies will be completed outside the scope of the TAP; Port staff will follow any progress made to provide status updates of the technology to interested terminal operators and partners.





## Vycon REGEN® System for Rubber-Tired Gantry Cranes

**Technology Manufacturer**  
VYCON Energy

**Co-Participants**  
Port of Los Angeles, Port of Long Beach, South Coast Air Quality Management District, California Air Resources Board, ITS, Evergreen and VYCON



### Background

The VYCON REGEN® system supports the goal of clean air and a healthier environment through the reduction of air pollution from port equipment. Specifically for this project, a rubber tire gantry (RTG) crane operating at each Port was retrofit with the VYCON system.

### Project Objective

Two marine terminals, ITS in the Port of Long Beach and Evergreen in the Port of Los Angeles, installed VYCON's REGEN system onto one of the terminals' rubber tire gantry (RTG) cranes.

### Technology Description

VYCON's REGEN system is an energy storage system that is also capable of supplying the stored energy on demand.

The REGEN system is re-charged each time the AC motor in the hoist regenerates power (i.e., on the down cycle). This stored energy is then quickly released back to the AC motors during the "up" cycle, resulting in increased efficiency during each lift cycle. The transitions are seamless and instantaneous. This conserves energy, increases fuel efficiency, and reduces emissions as well as operating costs. The REGEN System can be retrofitted onto in-use cranes or installed at the factory as part of a new crane.

### Results

The primary TAP role in this project was to co-fund emissions testing in support of CARB verification. This work was completed and VYCON received its Level 1 CARB verification in October, 2007.

### Typical Load Profile vs. Load Profile with REGEN

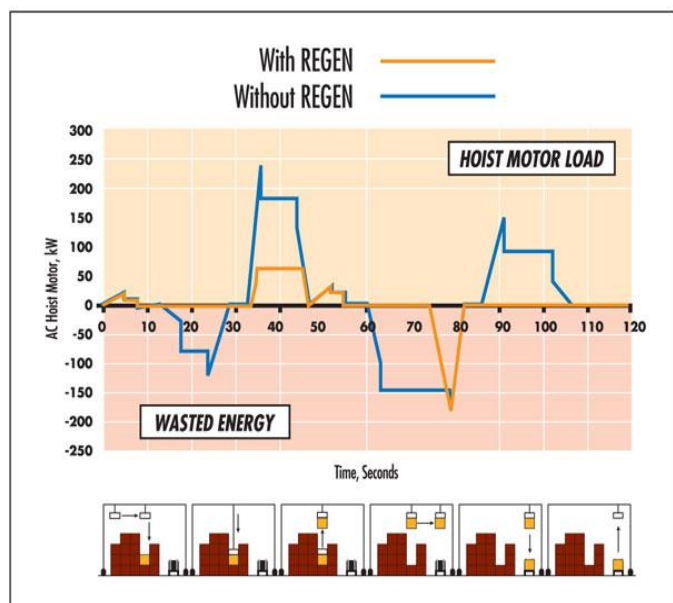

### Benefits

VYCON's REGEN system is verified to reduce particulate matter (PM) emissions by a minimum of 25 percent and is estimated to reduce oxides of nitrogen (NOx) emissions by 30 percent. Emissions of carbon dioxide (CO2) are estimated to be reduced by about 30 percent, resulting from the associated reduction in diesel fuel consumption up to 35 percent.

### Project Costs

The TAP supported the VYCON verification effort by co-funding emissions testing of the project equipment. Each Port committed \$11,500 for a total cost of \$23,000.

### Commercialization and Applications

The VYCON flywheel regeneration system already has a number of applications. In addition to the Level 1 RTG crane application, VYCON's REGEN system is also used in rail, uninterruptable power supply (UPS) and wind power applications.

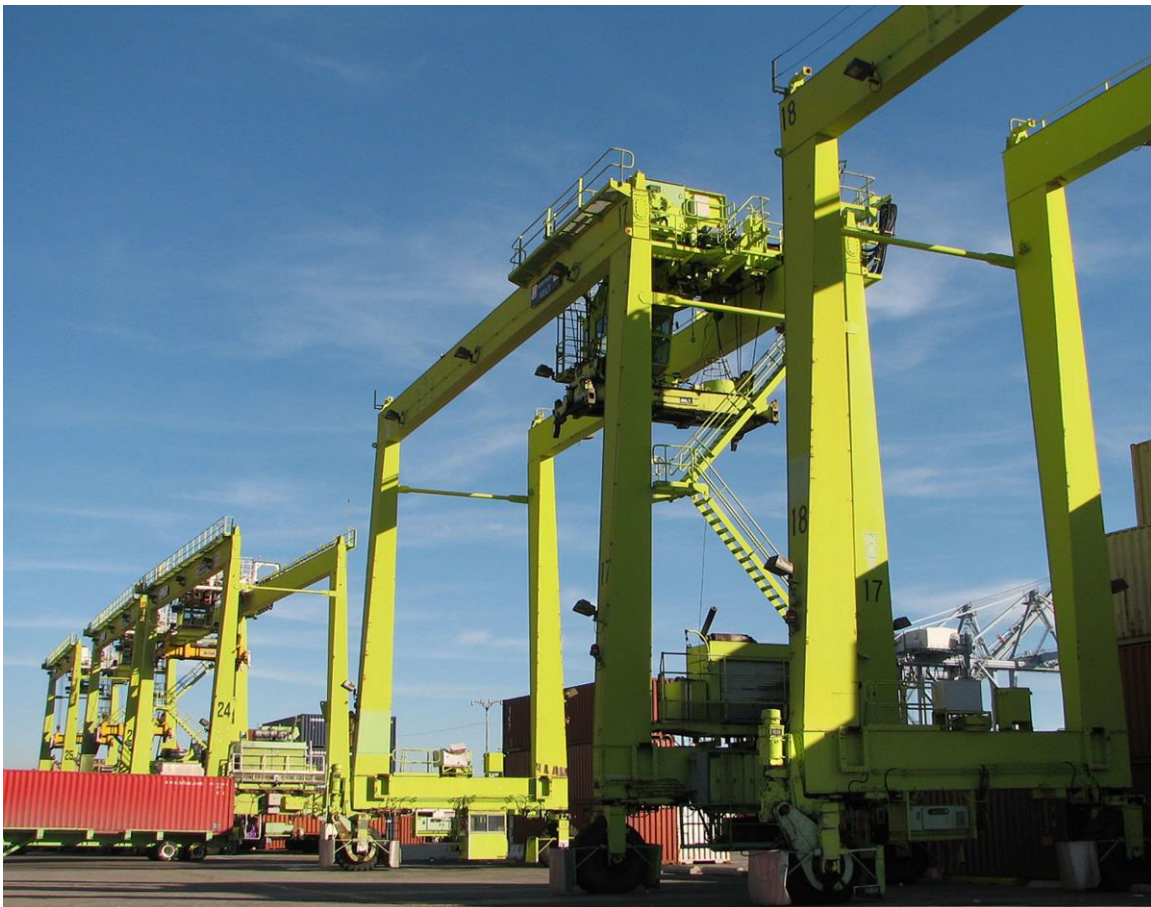

## Westport GX LNG Engine Development

### Technology Manufacturer

Westport Innovations  
Kenworth Truck Company

### Co-Participants

Port of Los Angeles, Port of Long Beach, South Coast Air Quality Management District, California Energy Commission

### Background

Westport Innovations (Westport), developer of the High Pressure/Direct Injection (HPDI) liquefied natural gas (LNG) fuel system technology, developed an LNG 15-liter heavy-duty truck engine that was certified to the 2010 on-road NO<sub>x</sub> emission standard of 0.2 grams per brake horsepower-hour (g/bhp-hr).

The 400- and 450-horsepower rated heavy-duty engines are based on the 15-liter Cummins ISX diesel engine platform and are designed to satisfy the performance requirements of class 8 tractors that provide drayage service at the Ports.

### Project Objective

The GX LNG heavy-duty engine development project had three primary objectives:

1. Development and certification of a 2007 LNG high-pressure direct-injection engine to 0.6 g/bhp-hr NO<sub>x</sub> by early 2008;
2. Establish the manufacturing capacity to produce LNG trucks in a high volume truck production facility;
3. Certification of a 0.2 g/bhp-hr NO<sub>x</sub> (2010 standard) compliant truck by early 2010 for deployment in mid-2010.

### Technology Demonstration

Westport's HPDI technology facilitates the use of natural gas as an engine fuel while retaining typical diesel engine combustion, power, and torque. The technology differs from other natural gas engines through the absence of spark plugs. A patented injector delivers a small amount of diesel fuel (approximately 6% by energy content) and high pressure natural gas directly to the engine combustion chamber, where the diesel fuel acts as the ignition source.

LNG fuel for the Westport GX engine is stored in the LNG tank mounted to the chassis of the vehicle. The liquid natural gas is drawn from the tank using a proprietary LNG pump that is powered by an engine-driven hydraulic pump. The LNG is then vaporized using excess heat from the engine's coolant system.

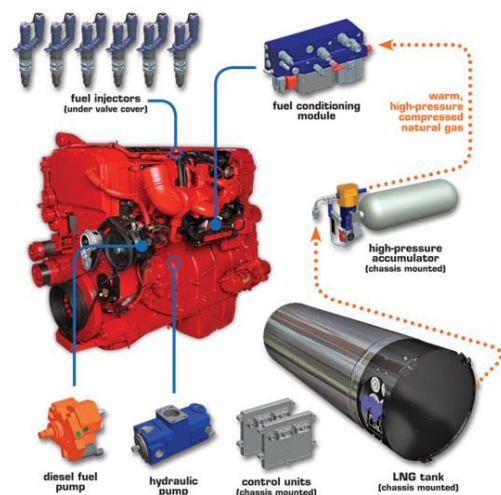

Simultaneously, a diesel fuel pump draws and pressurizes diesel fuel from its storage tank. Both the natural gas and diesel are then routed to a fuel conditioning module, where both fuels are pressure regulated, filtered, and sent to the fuel injector nozzles.

HPDI relies on late-cycle high pressure injection of natural gas into the combustion chamber. The natural gas is injected at the end of the compression stroke, similar to the diesel fuel in a diesel engine. Natural gas has a higher ignition temperature compared to diesel, so a diesel pilot injection is used to initiate combustion.

The benefits of the high pressure direct injection cycle include horsepower and torque output similar to a conventional diesel engine and fuel cost savings due to the high substitution of lower cost LNG as compared to diesel.

With the low emissions profile of natural gas and the high efficiency of the diesel combustion cycle, HPDI technology combines high energy efficiency with low emissions. The HPDI system extends beyond the fuel injection equipment, and is developed as a fully integrated system including fuel system management electronics, LNG tanks, and vehicle installation.

### Results

The Westport GX demonstrated emission levels during certification testing at or below 0.2 g/bhp-hr NO<sub>x</sub> in mid-2009. Westport worked closely with the U.S. EPA to finalize the deterioration rate for the engine. While this resulted in a slight delay in achieving final certification, the Westport GX heavy-duty LNG engine was granted a CARB Executive Order at the 0.2 g/bhp-hr NO<sub>x</sub> certification level on July 6, 2010.

### Benefits

The Westport GX LNG engine will accelerate NO<sub>x</sub> emission reductions by achieving the final 2010 standard in early 2010. Diesel engines of a comparable displacement are not expected to meet the 2010 standard initially – engine manufacturers will instead use credits generated from family emission level (FEL) engines to offset the higher emissions of their large displacement on-road engines. Westport estimates emission reductions of at least 0.45 tons of NO<sub>x</sub> per year per truck above the equivalent model year diesel truck, until the 0.2 standard is phased in for diesel engines. The LNG heavy-duty truck also emits 15 to 20 percent less greenhouse gases compared to diesel engines.

### Project Costs

The total project cost for development and certification of Westport GX natural gas engine is estimated at \$9,894,027. Westport contributed \$7,144,027 of the project development cost (in-kind) and secured additional funding in the amount of \$500,000 from Clean Energy, a provider of LNG fuel, to assist with integration of the engine and related fuel system. The California Energy Commission (CEC) provided \$500,000 under the PIER program. Kenworth Truck Company was a key partner in the project and will provide in-kind contributions to assist with the future deployment of GX-equipped LNG trucks. The SCAQMD contributed \$1.25 million, and the Ports of Long Beach and Los Angeles contributed \$250,000 in TAP funding.

### Commercialization and Applications

This large displacement, low emission natural gas engine is commercially available and can be used in port drayage, as well as other heavy-duty vehicle applications. For 2012, the engine is certified by CARB to have lower NO<sub>x</sub> emissions than the comparably sized diesel engine.